

INSTRUCTIONS
FOR USE

A-dec® 341pro/341flt

DUO DELIVERY SYSTEMS



a dec®

Copyright

© 2026 A-dec, Inc. All rights reserved.

A-dec, Inc. makes no warranty of any kind with regard to this material, including, but not limited to, the implied warranties of merchantability and fitness for a particular purpose. A-dec, Inc. shall not be held liable for any errors contained herein or any consequential or other damages concerning the furnishing, performance or use of this material. The information in this document is subject to change without notice. If you find any problems in the documentation, please report them to us in writing. A-dec, Inc. does not warrant that this document is error-free.

No part of this document may be copied, reproduced, altered, or transmitted in any form or by any means, electronic or mechanical, including photocopying, recording, or by any information storage and retrieval system, without prior written permission from A-dec, Inc.

Intellectual Property Rights

None of the trademarks, trade names, or proprietary symbols and icons in this document may be reproduced, copied, or manipulated in any manner without the express, written approval of the trademark owner.

A-dec, A-dec+, the A-dec design logo, and the trademarks listed at [a-dec.com/legal/trademarks](https://www.a-dec.com/legal/trademarks) are A-dec trademarks or registered trademarks in the United States and other countries. Certain touch control symbols and icons are proprietary to A-dec, Inc.

In the United States, Kerr and Dispos-a-Trap are trademarks or registered trademarks of Kerr Corporation. These may also be trademarks or registered trademarks in other countries.

Regulatory Information and Warranty

For required regulatory information and the A-dec warranty, see the *Regulatory Information, Specifications, and Warranty* document (p/n 86.0221.00) available in the Resource Center at www.a-dec.com.



For quick access to this document online, scan, tap, or click this QR code, which points to: [a-dec.com/regulatory-guide](https://www.a-dec.com/regulatory-guide).

Product Service

Product service is available through your local authorized A-dec dealer. For service information, or to locate an authorized dealer, contact A-dec at 1.800.547.1883 in the USA and Canada or +1.503.538.7478 worldwide, or visit www.a-dec.com.

Product Models and Versions Covered in This Document*

Models	Versions	Description
341pro/341fit	n/a	Delivery System

* Equipment shown in this document may include optional features or accessories. Some products, versions, and options in this document may not be available in certain regions.

Content Map

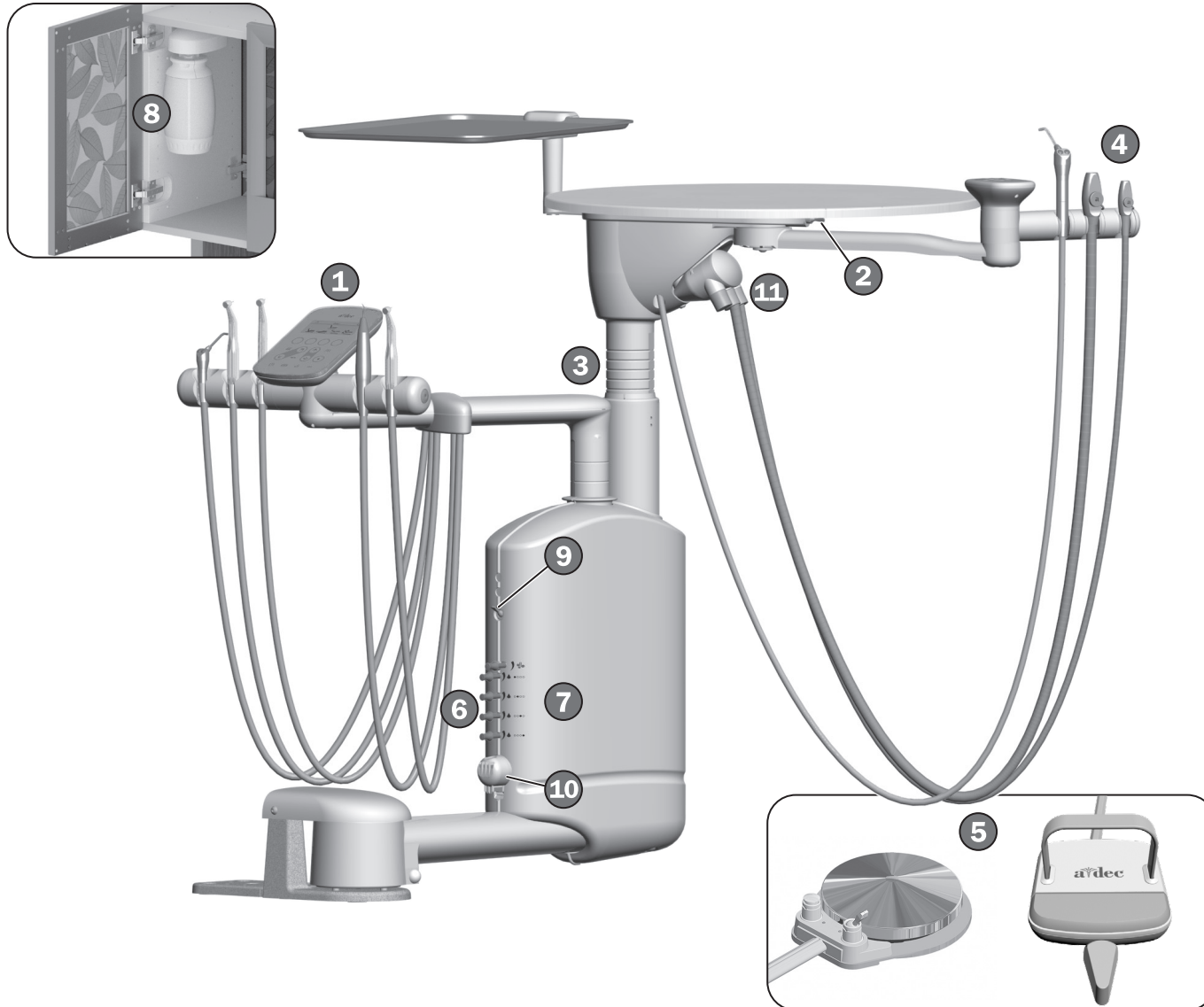

Features/Topics

1	Control Pads	8
2	Master Toggle	4
3	Worksurface and Instrumentation Height.....	5
4	HVE/Saliva Ejector	6, 21
5	Foot Control	7
6	Handpiece Coolant.....	13
7	Handpiece Drive Air	14
8	Self-Contained Water Bottle/ Waterline Maintenance	17
9	Handpiece Tubing Flush	18
10	Oil Collector	19
11	Solids Collector.....	20
	Utilities	25
	Specifications	26

Operate/Adjust

Turn On/Turn Off the Air, Water, and Power

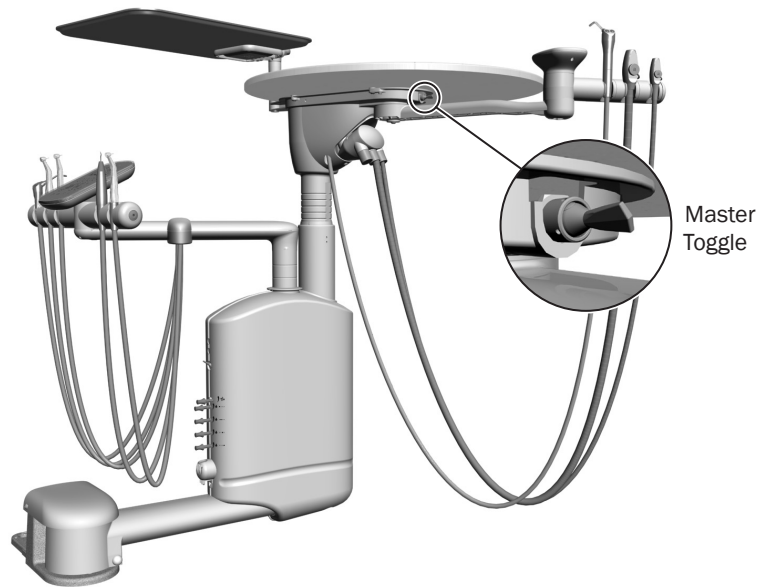

NOTE A-dec recommends that you perform a shock treatment on the dental unit waterlines before you use the system for the first time. For more information, see "Waterline Maintenance" on page 17.

Master Toggle

Use the master toggle to turn on the system air, water, and power. The toggle is located under the worksurface.

When to Turn Off the Power

To save energy and reduce the chance of air leaks, turn off the system power at the end of the work day and before longer periods of non-use.

Operate the Autoclavable Syringe

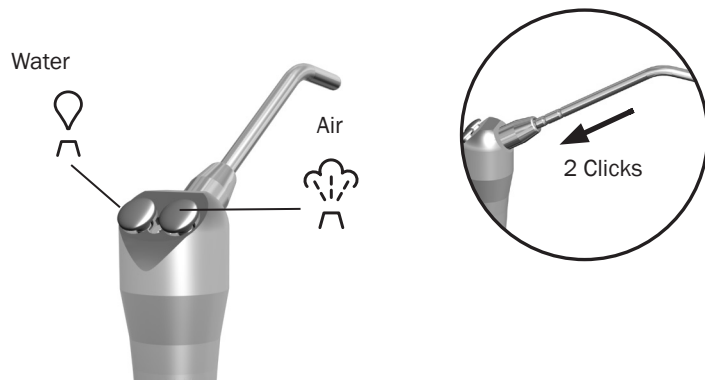

To install the A-dec syringe tip, push the tip in until you feel two clicks. Press both buttons simultaneously for the air/water spray.



IMPORTANT For more details on syringe usage and maintenance, see your A-dec syringe Instructions for Use.

Position the Instrument Holders

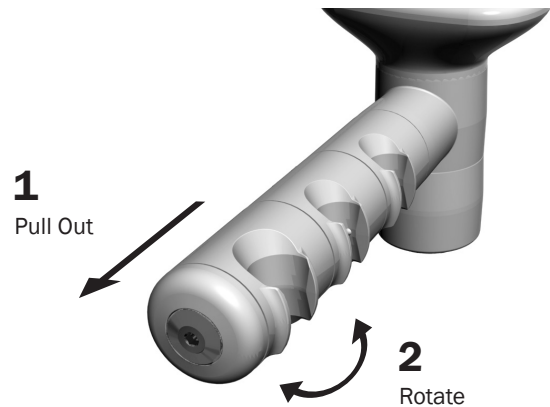

CAUTION Twisting the holder without pulling it away from the adjacent one will damage the mechanism.

You can adjust the instrument holders independently or as a set (on the doctor's side and the assistant's side).

1. Pull the holder, or holders, away from the touchpad/handle.
2. Rotate to the desired position and release.

Adjust the Worksurface and Instrumentation Height

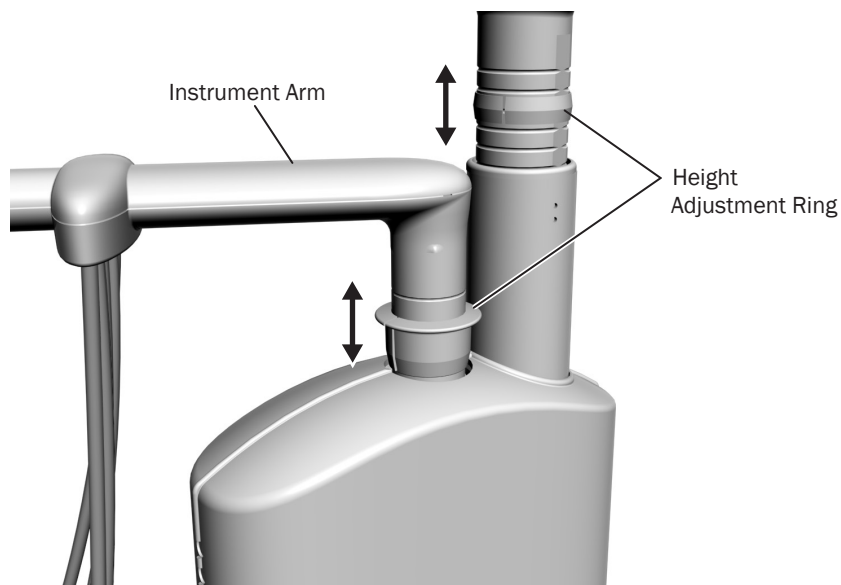

To adjust the height of the worksurface and the instrumentation arm:

1. Lift up the instrument arm or worksurface.
2. Slide the adjustment ring to the desired position.
3. Lower the instrument arm or worksurface post until the ring is securely seated.

HVE/Saliva Ejector Left/Right Conversion

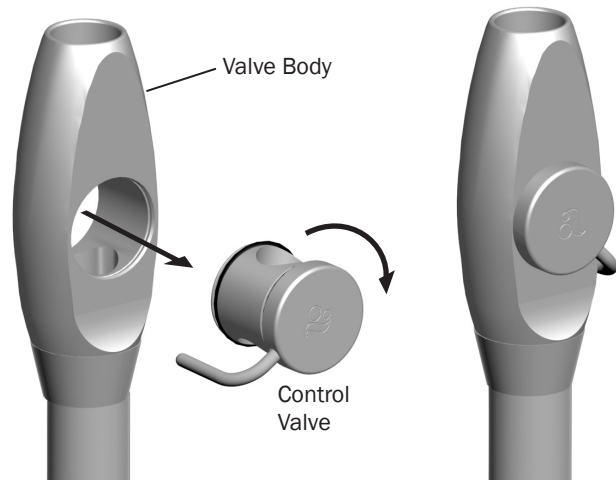

To convert the standard high-volume evacuator (HVE) and saliva ejector for left-handed operation, push the control valve out of the valve body, rotate the control valve 180°, and push it back into place.



NOTE Be sure to reinstall the valve on the same side of the valve body. Otherwise, the HVE or saliva ejector will not operate properly.

Operate the Foot Control

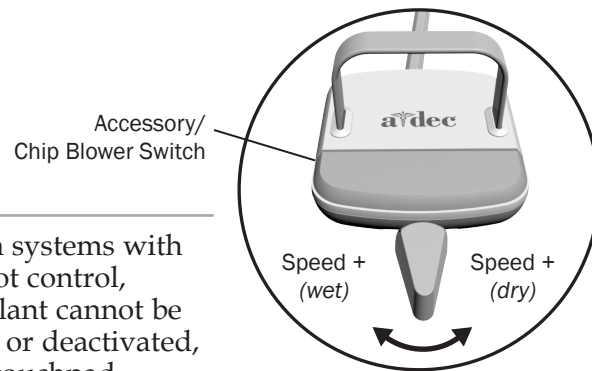
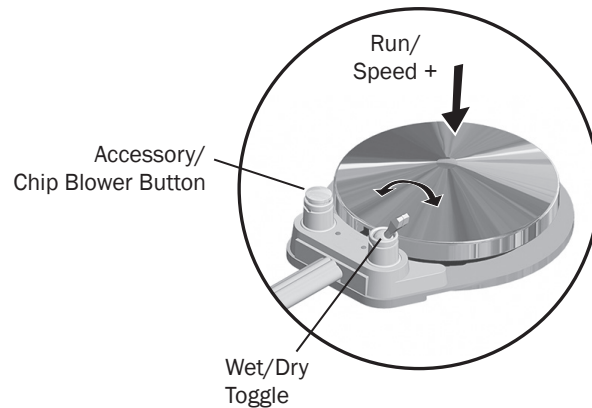

NOTE On systems with a lever foot control, water coolant cannot be activated, or deactivated, from the touchpad.



NOTE The lever foot control wet/dry function can be reversed by a technician (change left direction to dry, right direction to wet). For more details, contact your authorized A-dec dealer.

To activate a handpiece, lift it from the holder. Use the foot control to perform the desired handpiece operation.

Control	Operation	Procedure
Disc Foot Control	Run a handpiece.	Press on the disc. Push down to increase speed.
	Run a handpiece with or without water coolant.	CP5i control pad: Use the control pad to turn the coolant on or off, or flip the wet/dry toggle (which works as a three-way switch in conjunction with the control pad). Then press on the disc. CP5 control pad, standard touchpad, or no touch control: Flip the wet/dry toggle. Then press on the disc.
	Run the optional accessory/chip blower.	Press the accessory/chip blower button.*
	Operate the intraoral camera.	Press on the disc to capture an image.*
Lever Foot Control	Run a handpiece with water coolant.	Move the lever to the left. Move farther to increase speed.
	Run a handpiece without water coolant.	Move the lever to the right. Move farther to increase speed.
	Run the optional accessory/chip blower.	Press the accessory/chip blower switch.*
	Operate the intraoral camera.	Move the lever to the left or right to capture an image.*

* Contact your authorized A-dec dealer for questions about the operation or configuration of your integrated A-dec sanctioned clinical devices.

CP5i/CP5 Control Pads*



For touchscreen and control pad use, see the *A-dec DS7/CP5i/CP5 Touch Controls Instructions for Use* (p/n 86.0857.00) at a-dec.com/touchscreen-manual.



For configuring connectivity features, see the *A-dec+™ Software Platform Instructions for Use* (p/n 86.1030.00) at a-dec.com/connectivity-manual.



*Note. Touch control symbols and icons are proprietary to A-dec, Inc.

Standard Touchpad Controls*

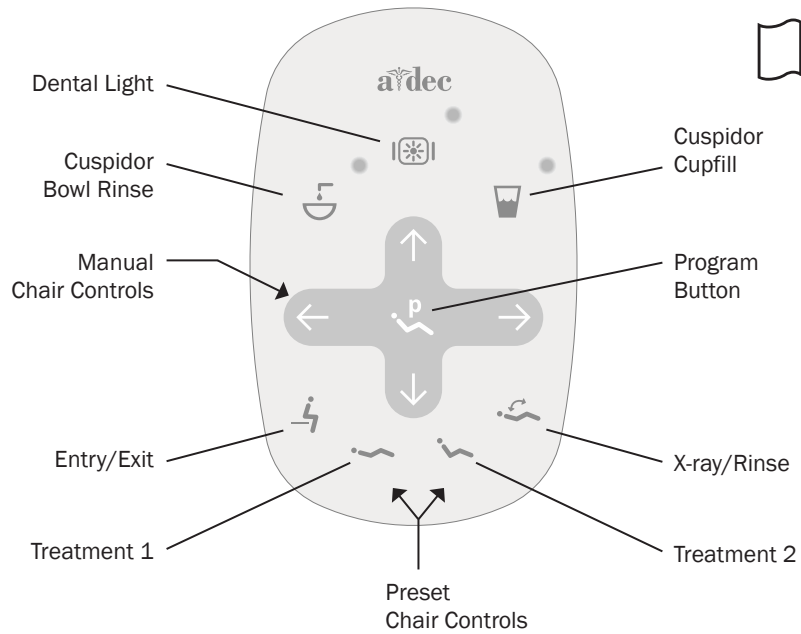

The A-dec standard touchpad and footswitch operate chair movement in the same way. See your dental chair Instructions for Use for detailed information about your footswitch controls.

The standard touchpad operates the chair, cuspidor, and dental light functions and provides manual and programmable controls.

*Note. Touch control symbols and icons are proprietary to A-dec, Inc.

Position the Chair with Manual Controls

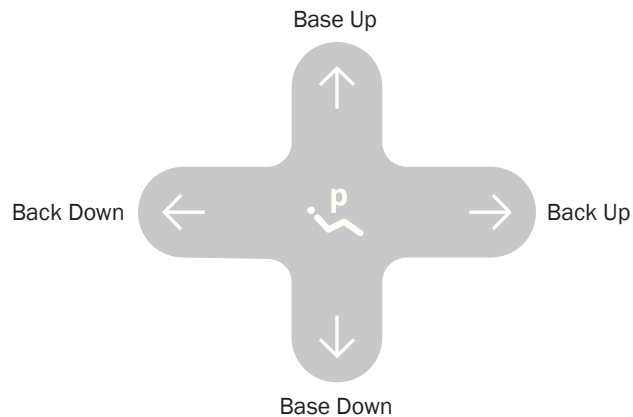
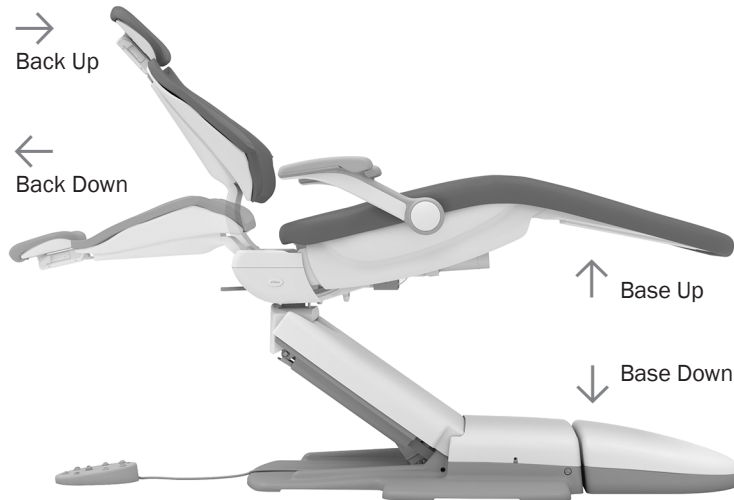

IMPORTANT The A-dec standard touchpad and footswitch move the chair in the same manner. For more details about footswitch controls, see your chair Instructions for Use.



WARNING Ensure that the patient is positioned safely before using the manual or preset chair controls. Never leave the patient unattended while the chair is in motion. Always take extra care with small children and patients with limited mobility.

To stop the chair at any point during preset movement, press any chair positioning button on the footswitch or touchpad.





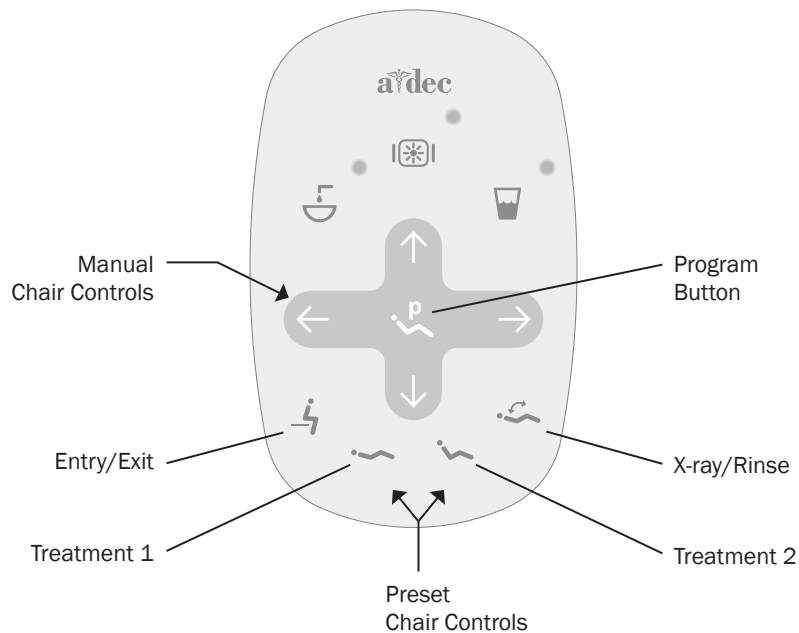

NOTE If you would like to adjust the maximum height of your chair, contact your local authorized A-dec dealer.

Icon/Function	Actions/Options
↑ Base Up	Press and hold ↑ to raise the chair base.
↓ Base Down	Press and hold ↓ to lower the chair base.
→ Back Up	Press and hold → to raise the chair back.
← Back Down	Press and hold ← to lower the chair back.



Position the Chair with Preset Controls





Press , , , or  to move the chair to a preset position. See the table (below left) for factory settings.

Customize the Chair Preset Positions





To customize chair presets , , and :





1. Position the chair as desired.
2. Press and hold  until you hear one beep, which indicates program mode is on.
3. Within five seconds, press the chair preset you wish to change (for example, press ). Three beeps confirm that your new setting is saved.

Customize the X-Ray/Rinse Chair Preset

The factory preset  moves the chair and patient into an upright position for x-rays or cuspidor access. A second press of  returns the chair to the previous position.

You can also set  to function as a customized chair preset position. To change its function:



1. Press  and  at the same time and hold for three seconds.
 - One beep indicates  is set as another customizable chair preset.
 - Three beeps indicate that  is set as the x-ray/rinse factory preset (which toggles between the x-ray/rinse position and the previous chair position).
2. If you set  as another customizable chair preset and want to assign a different chair position, follow the steps outlined above in “Customize the Chair Preset Positions.”

Icon	Preset Name	Factory Setting
	Entry/Exit	Positions the chair for patient entry/exit.
	Treatment 1	Positions the chair base and back down.
	Treatment 2	Positions the chair base down and the back partially up.
	X-Ray/Rinse	Moves the chair to either x-ray or rinse position. A second press moves the chair to the previous position.

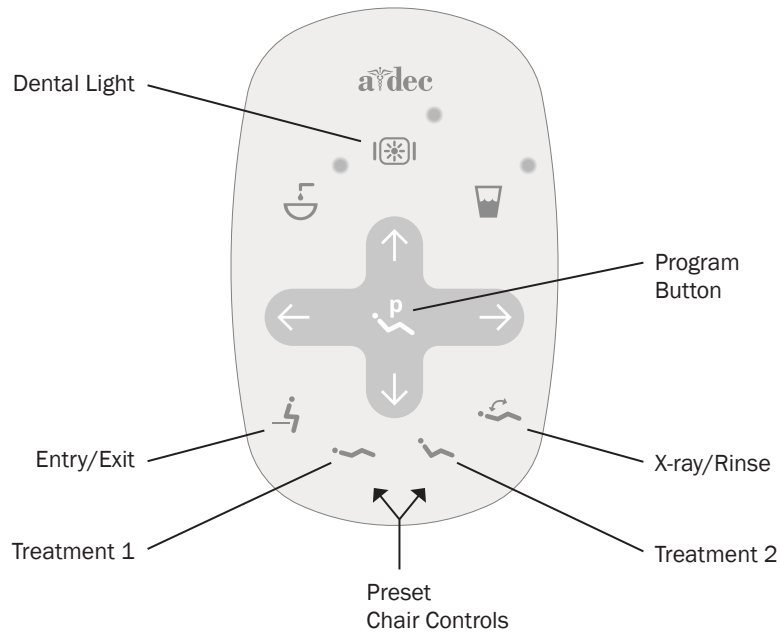



Operate the Dental Light



Turn On/Turn Off the Dental Light and Change the Intensity

- To turn on the light, press .
- To change the light intensity mode, press . The indicator light flashes continuously in cure-safe and composite/low modes.
- To turn off the light, press and hold .

Set the Dental Light Auto On/Off Function

When you press  and , the dental light automatically turns on once chair motion stops. The light turns off when you press  or .

To disable or enable this function, press and hold  and  at the same time.

- One beep indicates the function is off.
- Three beeps indicate the dental light auto on/off function is on.



IMPORTANT For more details on dental light operation, see your dental light Instructions for Use.

Adjust the Handpiece Coolant Spray

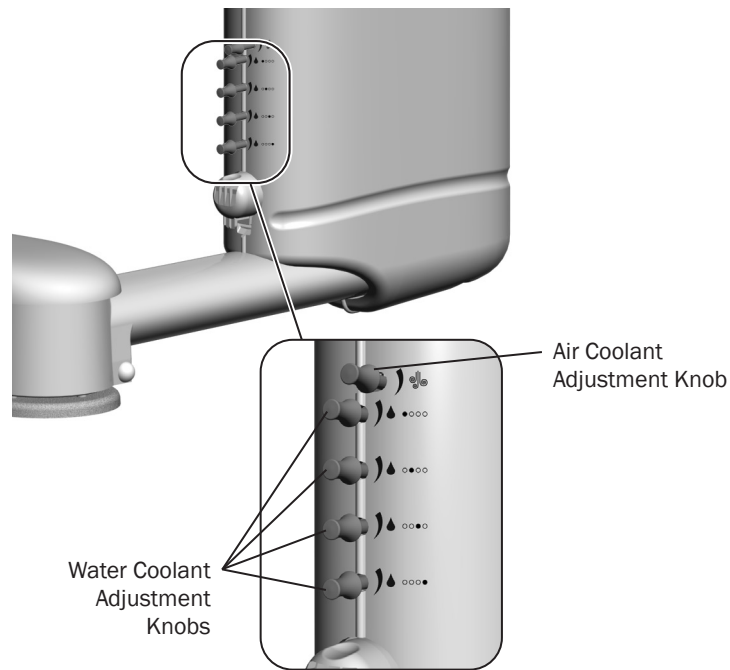

CAUTION When performing this procedure, do not attempt to completely shut off the water or air flow. The adjustment knobs are not designed to completely shut off flow and can damage the control block if you apply too much force.

The air coolant knob on your delivery system simultaneously adjusts air flow to all handpiece positions. Each water coolant knob adjusts water flow to a single position. Use the following process to adjust for the desired handpiece coolant atomization:

1. Insert a bur into each handpiece you are adjusting.
2. Turn the air coolant adjustment knob clockwise until it stops.
3. Withdraw a handpiece, and do one of the following:
 - **Disc foot control:** flip the wet/dry toggle to wet and press the disc all the way down.
 - **Lever foot control:** move the lever all the way to the wet.
4. Locate the water coolant adjustment knob for the handpiece position you are adjusting and turn it clockwise until coolant flow stops.
5. Slowly turn the water coolant adjustment knob counterclockwise until water droplets are expelled from every water port on the handpiece head. Return the handpiece to the holder.
6. Repeat steps 3 through 5 for each handpiece.
7. To set the coolant spray, withdraw a handpiece and turn the air coolant adjustment knob counterclockwise until you achieve the desired atomization at the cutting surface of the bur.



CAUTION Do not continue turning the air coolant adjustment knob counterclockwise after the air coolant stops increasing. The stem may come out of the control block.

8. If you require more water coolant, increase the water output in step 5 as needed.

Adjust Handpiece Drive Air Pressure

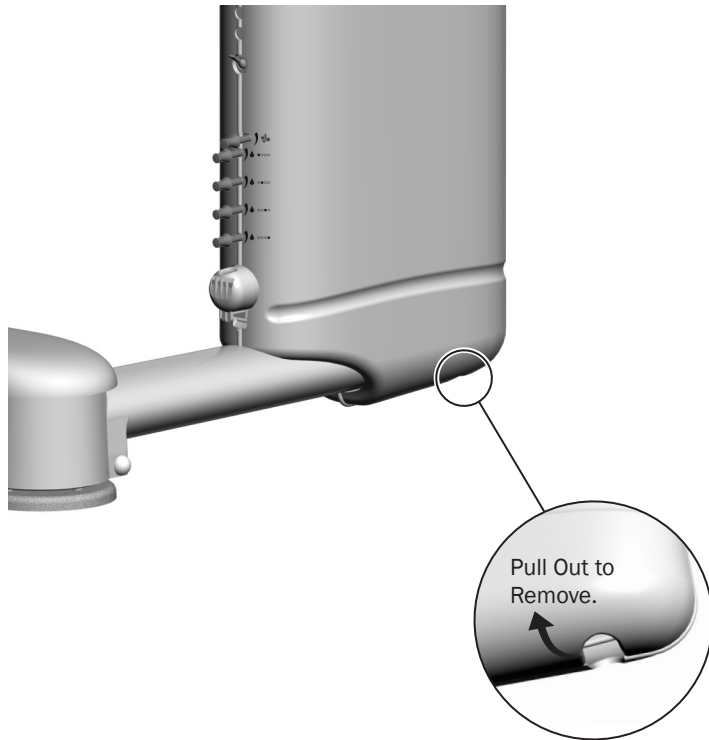

CAUTION Exceeding the manufacturer's recommended drive air pressure increases the risk of damage and may significantly decrease the life of your handpiece components. For the proper drive air pressure, see the handpiece manufacturer's Instructions for Use.



NOTE Drive air pressure varies throughout the system and can be more than 5 psi (34 kPa) lower at the handpiece than what is shown on the touchpad. To achieve the most accurate drive air measurement, use a handpiece pressure gauge attached to the handpiece tubing. To order a gauge, or for more information, contact your local authorized A-dec dealer.



WARNING Shock hazard. When you remove or replace the covers, take care not to damage any wiring or tubing. Verify that the covers are secure after you replace them.

To adjust handpiece driver air, first remove the delivery system covers. Locate the hole directly under the delivery system and pull the covers apart. To replace, position the covers over the delivery system and snap together.

Adjust Handpiece Drive Air Pressure *(continued)*

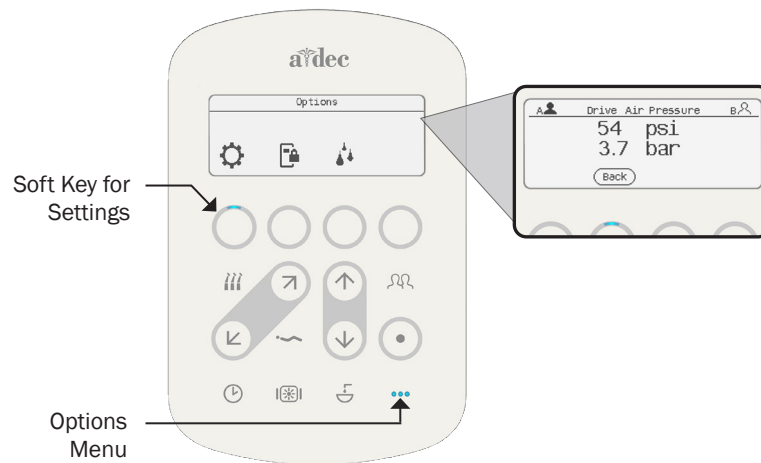
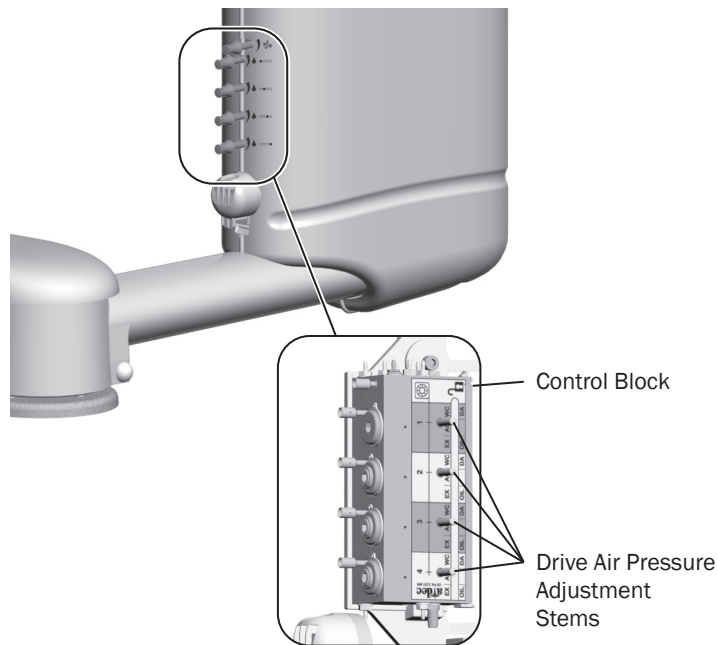

NOTE Drive air pressure may be lower at the handpiece than what is shown on the touch control. Pressure can also be measured with a handpiece pressure gauge.

To adjust the drive air pressure for each handpiece:

1. On the control pad, press ●●● to access the **Options** menu.
2. Press the soft key under the ⚙ icon.
3. Select **Diagnostics**.
4. Scroll down and select **Drive Air Pressure**.
5. Withdraw a handpiece.
6. Do one of the following:
 - **Disc foot control:** flip the wet/dry toggle to dry, and press the disc all the way down.
 - **Lever foot control:** move the lever all the way to dry.
7. Check the control pad screen to view the pressure reading.
8. Adjust the handpiece drive air pressure to meet the manufacturer's specifications. Turn the control stem clockwise to decrease flow and counterclockwise to increase flow.



CAUTION Exceeding the manufacturer's recommended drive air pressure increases the risk of damage and may significantly decrease the life of your handpiece components. For the proper drive air pressure, see the handpiece manufacturer's Instructions for Use.

Clean/Maintain

Protect with Barriers

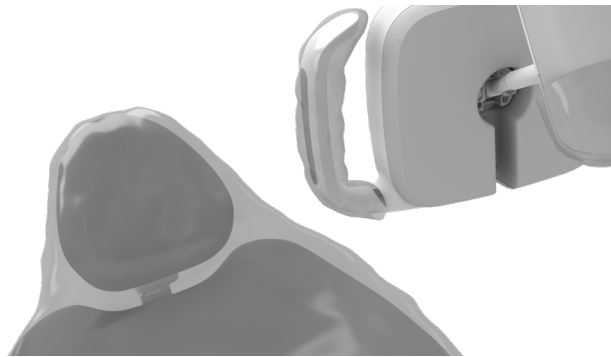

NOTE For proper use and disposal of barriers, see the barrier manufacturer's Instructions for Use.



IMPORTANT For recommendations on cleaning and chemical disinfection of touch and transfer surfaces (where barrier protection is not applicable or when barriers are compromised), please see the *A-dec Equipment Asepsis Guide* (p/n 85.0696.00).

A-dec recommends barrier protection for all applicable touch and transfer surfaces. Touch surfaces are areas that come into contact with hands and become potential cross-contamination points during dental procedures. Transfer surfaces are areas that come into contact with instruments and other inanimate objects.

In the USA, barriers must be produced under the Current Good Manufacturing Practice (CGMP) as specified by the U.S. Food and Drug Administration (USFDA). For regions outside the USA, refer to the medical device regulations specific to your location.

Waterline Maintenance



A-dec recommends that you use ICX Renew® dental unit waterline shock treatment* before you use the system for the first time.

For on-going waterline maintenance, A-dec recommends a three-part protocol:

- Continuous use of A-dec ICX® waterline treatment tablets
- Regularly monitor the water quality in your dental equipment
- Shock treatment whenever the test results exceed your established water quality action level



IMPORTANT For complete details on how to maintain good water quality, see the appropriate Instructions for Use provided with your A-dec waterline maintenance products.



For quick access to these documents online, scan, tap, or click this QR code, which points to: a-dec.com/waterline-manuals.

* *Note.* ICX Renew may be sold under different names in different regions.

Flush the Handpiece Tubing

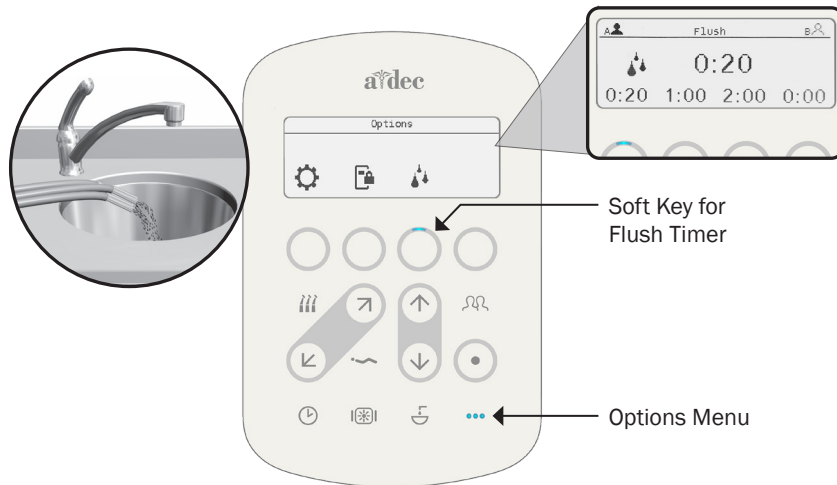

NOTE Flush all handpiece tubing (air and waterlines) in accordance with the regulations in your area. If no regulations exist, flush the tubing for a minimum of 20–30 seconds at the beginning of the day and after each patient.

Systems with CP5i Control Pad

Use the flush feature on the control pad to move a high volume of water through the handpiece tubing. To flush the tubing after each patient:

1. Disconnect the handpieces and hold the tubing over a sink, cuspidor bowl, or basin.
2. On the control pad, press ●●● to access the **Options** menu.
3. Press the soft key under 🚰 for the flush timer.
4. Select the soft key for desired flush time. (*Note. For more details on flush timer options, see the A-dec Touchscreens and Control Pads Instructions for Use.*)

Systems with Standard Touchpad, CP5 Control Pad, or No Touch Control

Use the flush toggle on the back of the control head to move a high volume of water through the handpiece tubing. To flush the tubing after each patient:

1. Disconnect the handpieces.
2. Disconnect the handpieces and hold the tubing over a sink, cuspidor bowl, or basin.
3. Flip the flush toggle up and hold for the appropriate amount of time.

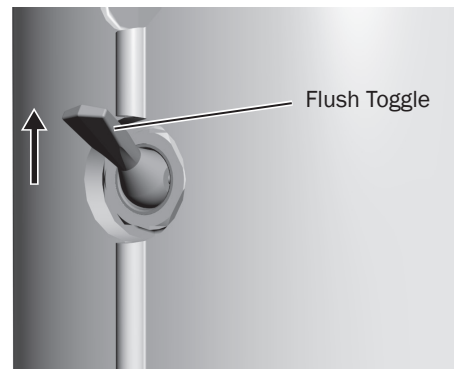

Maintain the Oil Collector

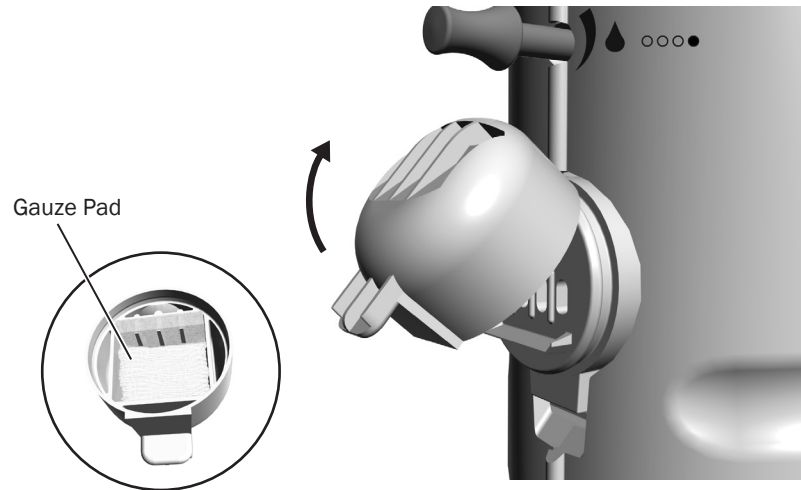

Service the oil collector on the delivery system once a week for normal use and more often for heavier use. To service:

1. Unsnap the oil collector cover from the delivery system and discard the old gauze. Do not remove the foam muffler.
2. Fold a new gauze pad (2" x 2" [51 mm x 51 mm]) into quarters and place it inside the cover.
3. Snap the oil collector cover closed.

Maintain Solids Collector

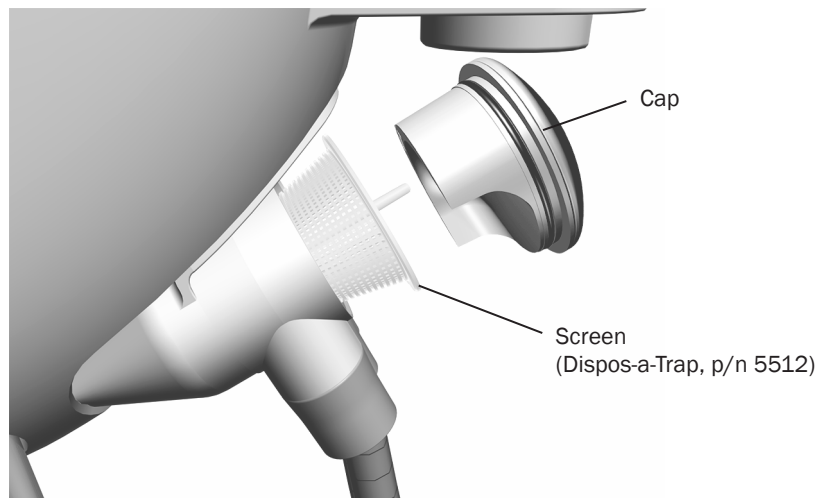

WARNING Infectious waste may be present. Follow asepsis protocol to prevent cross contamination.

The solids collector helps prevent solids from entering the central vacuum system. To ensure proper suction from the central vacuum and maintain proper treatment room asepsis, discard and replace the solids collector screen at least twice a week.



TIP To obtain replacement solids collector screens, contact your authorized A-dec dealer and reference the Kerr® Dispos-a-Trap™ (p/n 5512).

To replace the solids collector screen:

1. Turn off the vacuum or open the HVE control valve.
2. Remove the solids collector cap.



CAUTION Do not empty the screen into your cuspidor. Doing so could plug the drain.

3. Remove the solids collector screen and discard according to your local regulations.



NOTE When you replace the solids collector cap, ensure that the keyed cutout faces down, or it will cut off the vacuum flow.

4. Insert a new screen in the solids collector and replace the cap.

A-dec HVE/Saliva Ejector Valve Body Assembly Asepsis

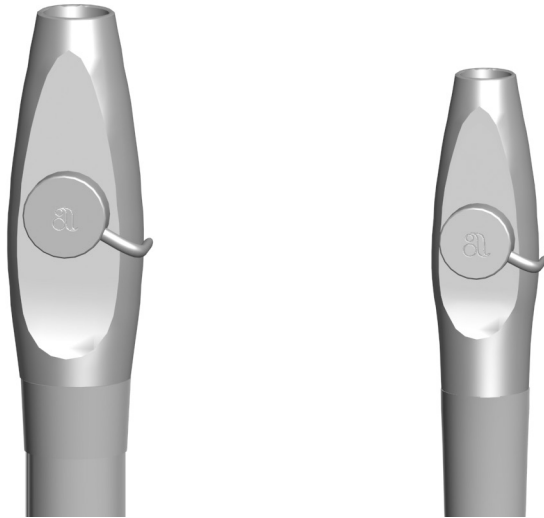

NOTE Vacuum lines should be flushed at the end of each day or more frequently according to your clinic's protocols.

If you use barriers to protect the main body of the HVE and saliva ejector, replace the barriers after each patient. Clean and disinfect these instruments at the end of each day or after each patient if the barriers have been compromised. If you do not use barriers, or if you perform oral surgery, always clean and disinfect these instruments after each patient.

Cleaning and Disinfection



CAUTION Clean the valve body assembly as soon as possible after treating each patient. Do not allow blood and debris to dry on instruments. If you cannot clean it immediately, keep the valve body assembly moist.



NOTE Use an intermediate-level EPA-registered hospital-grade disinfectant containing a tuberculocidal claim with one of the following compositions: high-dilution water-based phenolic formulation or quaternary ammonium compound with less than 25% isopropanol.



NOTE If using a spray solution, spray on a soft, low-lint wipe to apply solution to the valve body assembly.

To clean and disinfect the HVE and saliva ejector valve body assembly without disconnecting from the vacuum system:

1. Remove the vacuum tip from the HVE or saliva ejector valve body assembly. Discard disposable vacuum tips.

A-dec HVE/Saliva Ejector Valve Body Assembly Asepsis *(continued)*

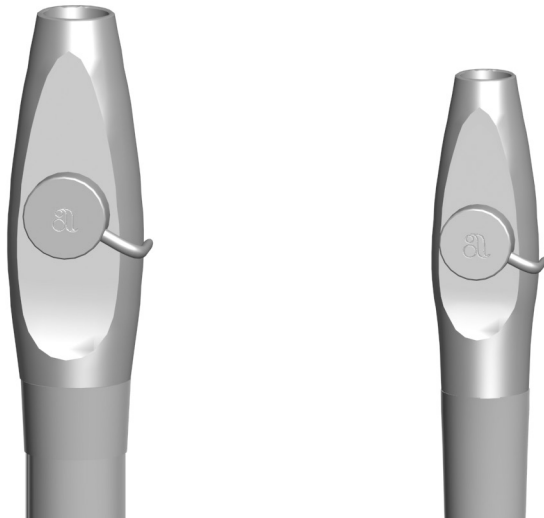

2. Clean the valve body assembly to remove visible soil using a disinfectant wipe or spray solution. Keep the valve body assembly wet according to the manufacturer's recommended contact time. Repeat, if necessary, until the valve body assembly is visibly clean.
3. Disinfect the valve body assembly using a new disinfectant wipe or spray solution. Keep the valve body assembly wet according to the manufacturer's recommended contact time.
4. Allow the valve body assembly to air dry.
5. Operate the HVE and the saliva ejector valves several times to verify that they rotate smoothly.

Routine Maintenance and Sterilization



CAUTION Clean the valve body assembly as soon as possible after treating each patient. Do not allow blood and debris to dry on instruments. If you cannot clean it immediately, keep the valve body assembly moist.



NOTE A-dec valve body assemblies are heat tolerant for sterilization. Users may sterilize at their discretion.

To routinely maintain and sterilize the HVE and saliva ejector when disconnected from the vacuum system (frequency determined by the user):

1. Remove the valve body assembly from the vacuum line by pulling it away from the tubing at the tailpiece.
2. Disassemble the valve body by pushing the control valve out of the valve body.
3. Clean soiled valve body components using a soft, low-lint wipe.

A-dec HVE/Saliva Ejector Valve Body Assembly Asepsis *(continued)*

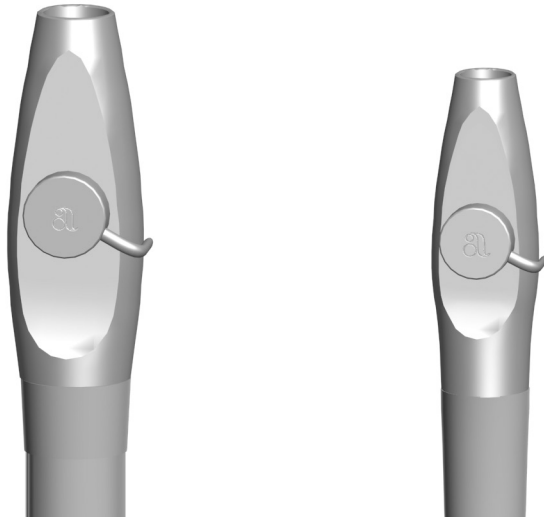

4. Prepare a warm (32-43°C [90-110°F]) detergent solution (neutral pH enzymatic detergent or alkaline non-enzymatic detergent), according to the manufacturer's recommended instructions.
5. Soak soiled valve body components in the prepared detergent solution for at least one minute or for as long as the manufacturer's recommended instructions indicate (whichever is longer).
6. Inspect O-rings. Remove, discard, and replace if there are visible signs of damage.
7. Use a soft, nylon-bristle brush, or equivalent, to scrub the:
 - Exposed surface of the valve body components, while submerged, for a minimum of 30 seconds or until all visible soil has been removed.
 - Interior lumen of the valve body at least three times (in and out), clearing any visible soil from brush bristles.
8. Rinse the cleaned valve body components under flowing, warm (32-43°C [90-110°F]) potable water for a minimum of 30 seconds.
9. Allow valve body components to air dry.
10. Sterilize the valve body components according to the following:
 - Dynamic air-removal sterilizers: 4 minutes at 132-135°C (270-275°F)
 - Gravity-displacement sterilizers: 30 minutes at 121-123°C (250-254°F)
11. Allow the load to dry for 30 minutes before removing it from the sterilizer. Ensure the valve body components are completely dry before proceeding.

A-dec HVE/Saliva Ejector Valve Body Assembly Asepsis *(continued)*

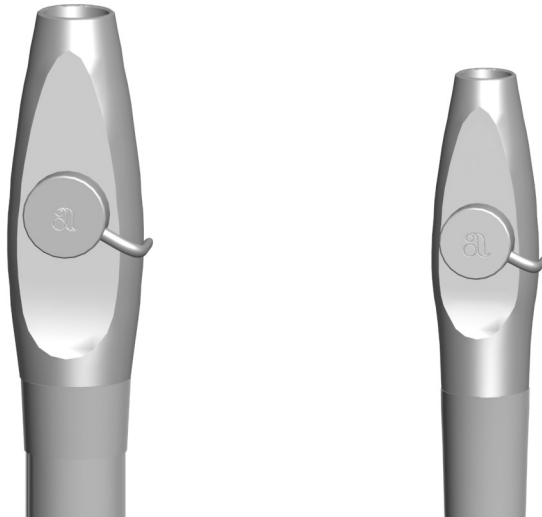

HVE/Saliva Ejector Tips



CAUTION Use only silicone lubricant when lubricating the black O-rings in A-dec instruments. Petroleum-based products will cause permanent damage to the O-rings.

12. Prior to use, lubricate O-rings with A-dec silicone lubricant, and reassemble the valve body assembly.
13. Reinstall the valve body assembly on the tubing tailpiece.
14. Operate the HVE and the saliva ejector control valves several times to verify that they rotate smoothly.



NOTE Select tips that are compatible with your HVE and saliva ejector openings. See “A-dec HVE/Saliva Ejector Tip Connections” on page 26 for specifications.

Disposable Tips



CAUTION Disposable HVE and saliva ejector tips are not sterilizable and should not be reused.



Replace disposable HVE and saliva ejector tips after each use.

Bulb for Fiber-Optic Tubing

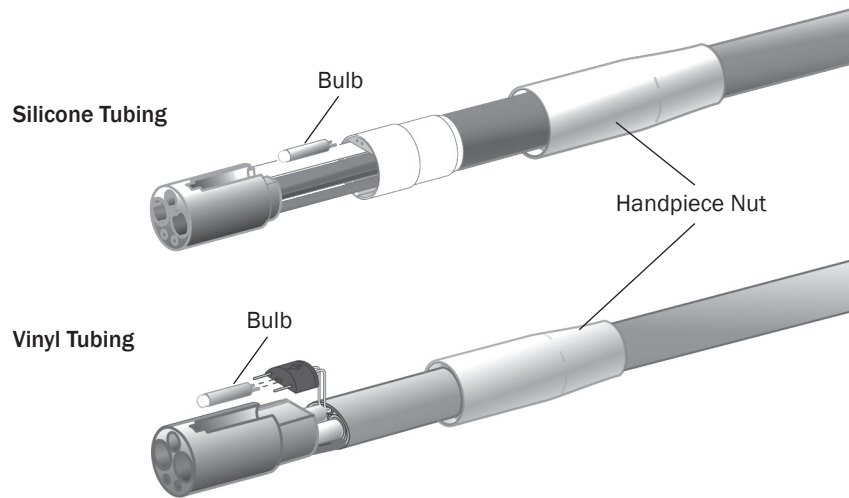

IMPORTANT To replace the bulb in your handpiece or quick-disconnect coupling, see your handpiece Instructions for Use.

To replace the bulb in your fiber-optic 5-hole silicone or vinyl tubing:

1. Disconnect the handpiece and quick-connector coupling from the tubing.
2. Pull back the metal handpiece nut.
3. Slide back the metal portion of the handpiece terminal (silicone tubing only).
4. Replace the bulb.
5. Reinsert the metal portion of the terminal into the plastic portion (silicone tubing only).
6. Carefully slide the handpiece nut back over terminal.

Access the Utilities

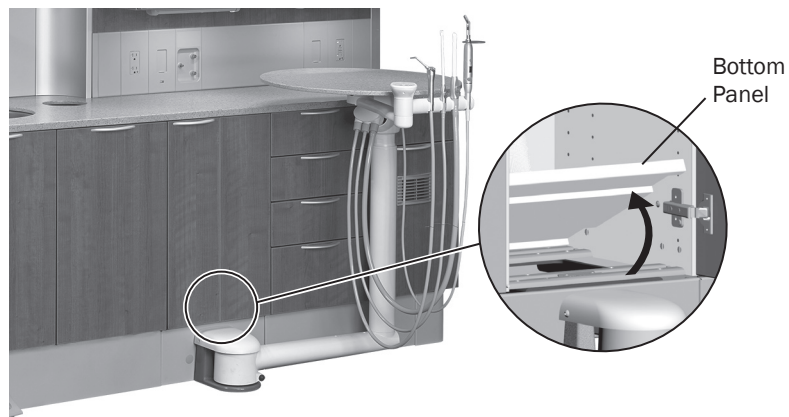

CAUTION When you remove or replace the panel, take care not to damage any wiring or tubing. Verify that the panel is secure after you replace it.

The system utilities are located in the cabinet base and typically include the electrical outlet, as well as the system hookups for air, water, and vacuum. To access, open the doors of the cabinet, then lift and remove the bottom panel. For maintenance, contact your local authorized A-dec dealer.

Specifications



System Accessory Load

Maximum accessory load capacity: 20 lb (9.1 kg)
(in addition to integrated accessories)

A-dec HVE/Saliva Ejector Tip Connections

Standard 11 mm HVE: 11 mm (0.433") diameter opening
(for standard HVE tips)

Large bore 15 mm HVE: 15 mm (0.591") diameter opening
(for standard HVE tips)

Standard 6 mm SE: 6 mm (0.236") diameter opening
(for standard HVE tips)

Solids Collector Screen/Filter

Maximum mesh opening size: 0.047" (1.194 mm) \cong 1200 μ m



IMPORTANT For electrical specifications, identification of symbols, and other regulatory requirements, see the *Regulatory Information, Specifications, and Warranty* document (p/n 86.0221.00) available in the Resource Center at www.a-dec.com.



For quick access to this document online, scan, tap, or click this QR code, which points to: a-dec.com/regulatory-guide.



NOTE Specifications are subject to change without notice. Requirements may vary depending on your location. For more information, contact your authorized A-dec dealer.



 **A-dec Headquarters**

2601 Crestview Drive
Newberg, Oregon 97132
United States
Tel: 1.800.547.1883 within USA/CAN
Tel: +1.503.538.7478 outside USA/CAN
www.a-dec.com

A-dec Australia

Unit 8, 5-9 Ricketty Street
Mascot, NSW 2020
Australia
Tel: 1.800.225.010 within AUS
Tel: +61.(0).2.8332.4000 outside AUS

A-dec United Kingdom

Austin House, 11 Liberty Way
Nuneaton, Warwickshire CV11 6RZ
England
Tel: 0800.ADEC.UK (2332.85) within UK
Tel: +44.(0).24.7635.0901 outside UK



86.1065.00 Rev C
Date of Issue 2026-01-29
Copyright 2026 A-dec, Inc.
All rights reserved.

IFUnewcov5