

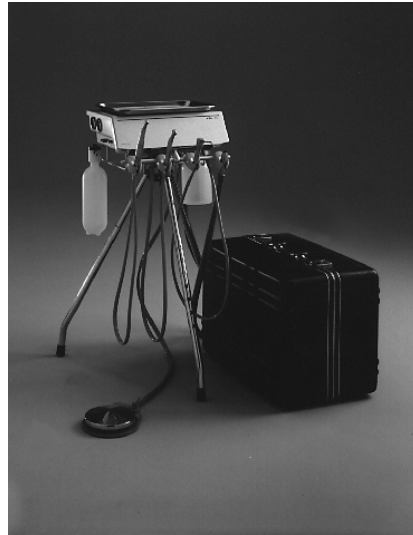

A-dec Pac I (Portable) Model 3420

Instructions for Use and Maintenance



Pac I Field Unit



Pac I Self-Contained Unit

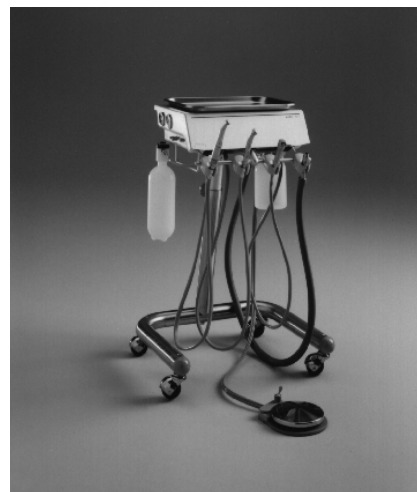

Pac I Institutional Unit

Copyright

© 2024 A-dec, Inc. All rights reserved.

A-dec, Inc. makes no warranty of any kind with regard to this material, including, but not limited to, the implied warranties of merchantability and fitness for a particular purpose. A-dec, Inc. shall not be held liable for any errors contained herein or any consequential or other damages concerning the furnishing, performance or use of this material. The information in this document is subject to change without notice. If you find any problems in the documentation, please report them to us in writing. A-dec, Inc. does not warrant that this document is error-free.

No part of this document may be copied, reproduced, altered, or transmitted in any form or by any means, electronic or mechanical, including photocopying, recording, or by any information storage and retrieval system, without prior written permission from A-dec, Inc.

Trademarks and Additional Intellectual Property Rights

A-dec, the A-dec logo, A-dec 500, A-dec 300, Cascade, Cascade Master Series, Century Plus, Continental, Decade, ICX, ICV, Performer, Preference, Preference Collection, Preference ICC, and Radius are trademarks of A-dec, Inc. and are registered in the United States and other countries. A-dec 400, A-dec 200, Preference Slimline, and reliablecreativesolutions are also trademarks of A-dec, Inc. None of the trademarks or trade names in this document may be reproduced, copied, or manipulated in any manner without the express, written approval of the trademark owner.

Certain touchpad symbols are proprietary to A-dec, Inc. Any use of these symbols, in whole or in part, without the express written consent of A-dec, Inc. is strictly prohibited.

Regulatory Information and Warranty

For required regulatory information and the A-dec warranty, see the *Regulatory Information, Specifications, and Warranty* document (p/n 86.0221.00) available in the Resource Center at www.a-dec.com.



For quick access to this document online, scan, tap, or click this QR code, which points to a-dec.com/regulatory-guide.

Product Service

Product service is available through your local authorized A-dec dealer. For service information, or to locate an authorized dealer, contact A-dec at 1.800.547.1883 in the USA and Canada or 1.503.538.7478 worldwide, or visit www.a-dec.com.

Contents

Setup and Repacking	4	Self-Contained Water System.....	17
Institutional Unit and Self-Contained Unit	4	Steril-Vac	18
Field Unit	4	Oil Collection System	20
Place the Handpiece Tubings and Syringe in the Holders.....	7	Care Instructions	20
Install the Self-Contained Water Bottle.....	7	Maintenance	21
Install the Steril-Vac	7	General Service Information.....	21
Install the Optional Air Saliva Ejector	7	How Your Pac I Works.....	23
Install the Tray Holder	8	Basic Troubleshooting	26
Connect the Supply Air Tubing	8	Air Filter/Regulator Maintenance.....	27
Pac I Field Repair Kit and (Optional) Tool Kit.....	9	Century II Control Block Maintenance	28
Testing Your Pac I Unit.....	9	Foot Control III Valve Maintenance	33
Repacking the Pac I Field Unit	9	Signal Relay Valve Maintenance.....	35
Instructions for Use	10	Flush Valve Maintenance.....	36
About Your Pac I Dental Unit.....	10	Handpiece Selector Valve Maintenance	37
Control Functions	11	Autoclavable Syringe Maintenance.....	38
Air Pressure Gauges.....	12	Steril-Vac Maintenance.....	42
Foot Control	12	Pac I Tool and Repair Kits.....	43
Routine Adjustments	13	Warranty	44
Autoclavable Syringe	14		
Handpiece Tubing Flush System	17		

How to Use This Manual

This manual describes your Pac I Portable Delivery System, Model 3420. Your manual is divided into three sections: Set-up and repacking, operation, and maintenance. Each section addresses specific information. The following list of questions should help you determine which section to check when you need information.

Set-up and Repacking

- The unit just arrived, how do I set it up?
- How do I repack the field unit for transportation or storage?

Operation

- How do I operate it?
- What do the controls do?
- How do I make routine adjustments?
- What do the accessories do?
- How do I clean it?

Maintenance

- How does the unit work?
- What are the major components?
- Something is wrong, how can I fix it?

We understand that you may be using this portable dental delivery system virtually anywhere. For this reason, we have made the Maintenance section quite comprehensive. If you have questions after reading the appropriate section(s), contact your authorized A-dec dealer.

Setup and Repacking

Follow the instructions for your model.

Institutional Unit and Self-Contained Unit

Assemble the U-Frame (Institutional Unit Only)

1. Using a 1/4" hex key, attach the upright support to the U-frame with the 1-1/4" (32 mm) long socket head screw.



Mount the Control Head

1. Align the control head mounting hub with the U-frame upright support and place the control head on the upright support.



Institutional Unit Shown

2. Using a 5/32" hex key, tighten the setscrew in the control head hub.

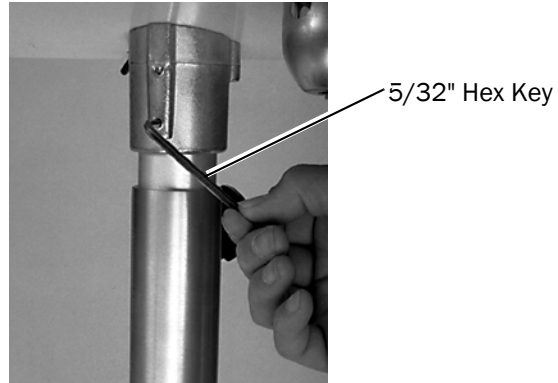

Institutional Unit Shown

3. Place the foot control where desired.

Go to "Place the Handpiece Tubings and Syringe in the Holders" on page 7.

Field Unit

Assemble the Tripod Base

1. Remove the foot control and place it on top of the control head.

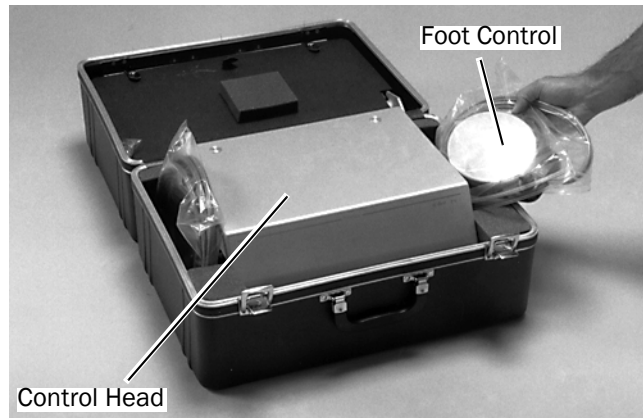

2. Remove the supply air tubing and set it aside.

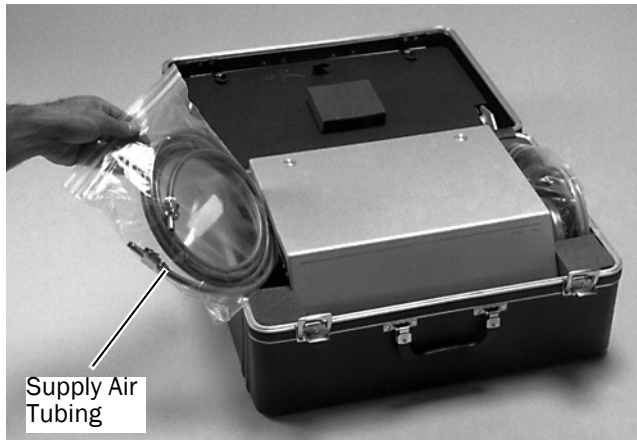

5. Remove the tripod.

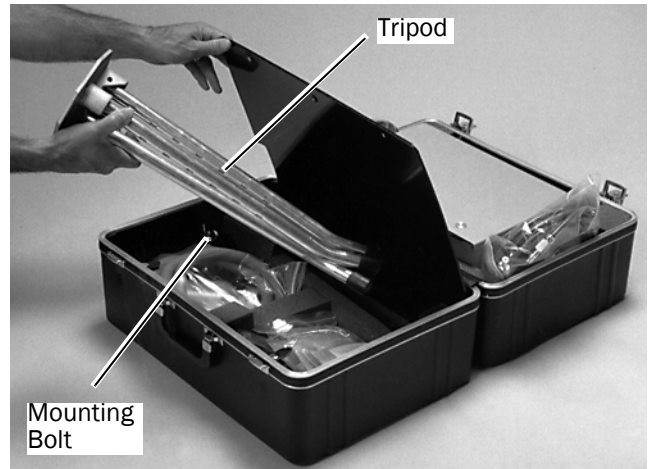

3. Unsnap the divider to access the other side of the case.
4. If your unit is equipped with the (optional) second tray and tray holder, remove them and set aside.

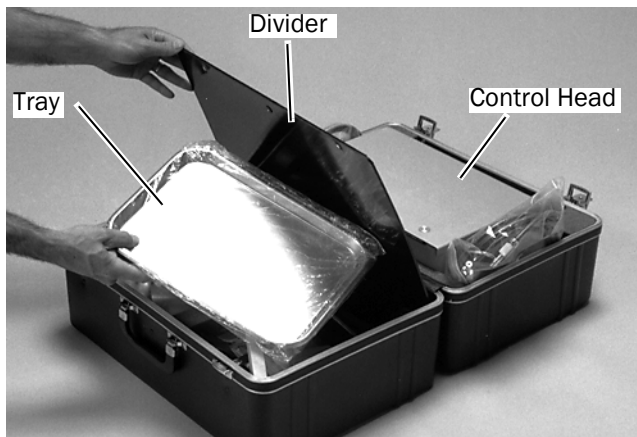

6. Remove the mounting bolt assembly.



7. Adjust the tripod legs to the desired height. We recommend the highest setting for setup.

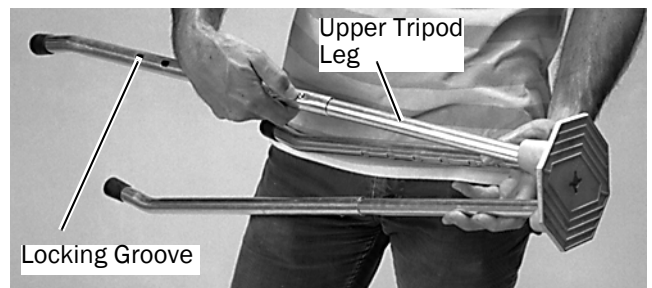

8. Insert the mounting bolt up through the slot in the bottom of the tripod.
Secure the bolt to the tripod by turning it 90° to align the locking pin with the pin groove.

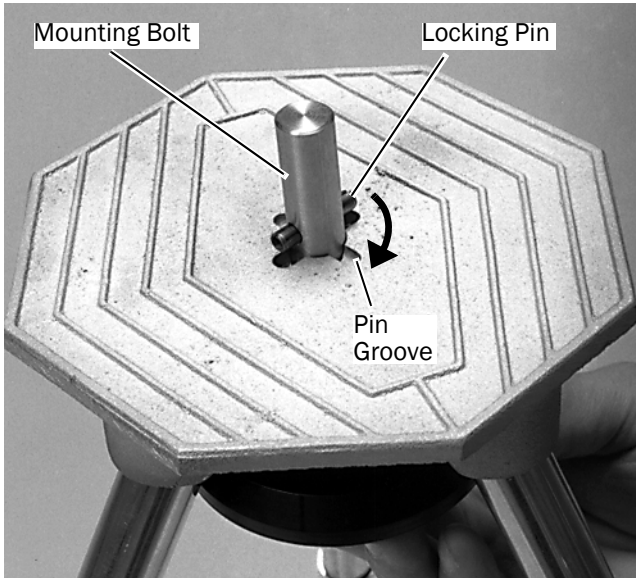

9. Tighten the wing nut.

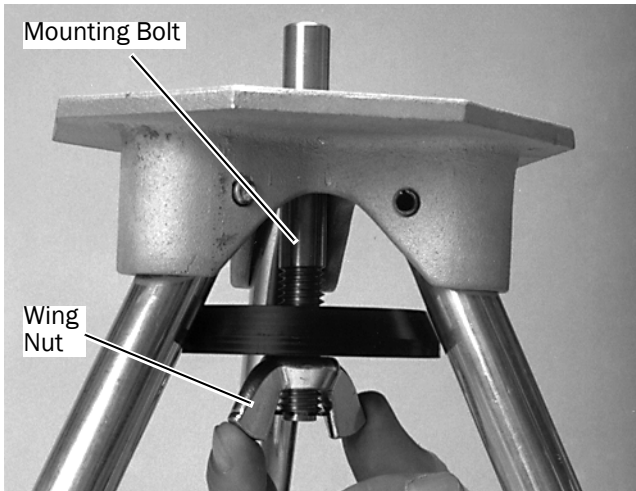

Mount the Field Unit Control Head

1. Remove the control head and foot control from the case, and then place the mounting hub of the control head on the mounting bolt.



2. Tighten the mounting hub thumbscrew.

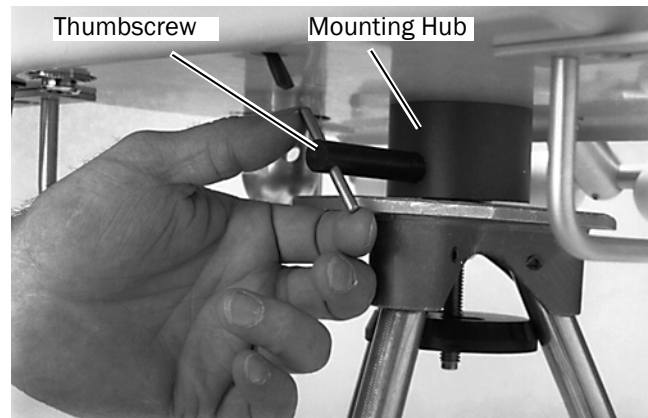

Place the Handpiece Tubings and Syringe in the Holders

1. Lift the control head cover.
2. Remove the handpiece tubings and the syringe, and then place them in the holders. The tools provided vary depending on the system that was ordered.

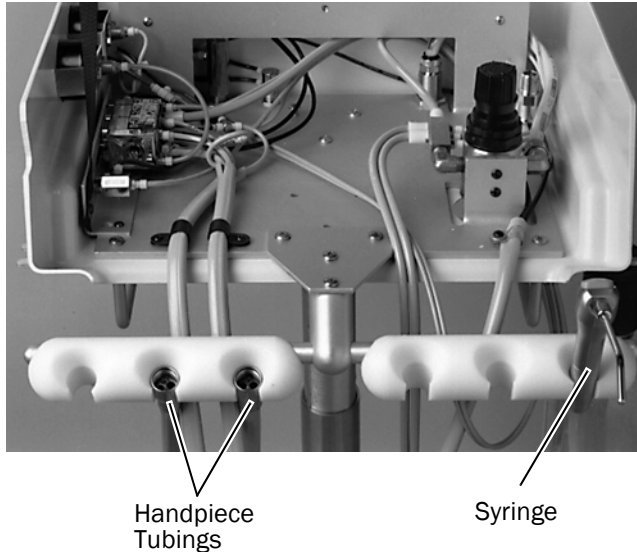

Install the Self-Contained Water Bottle

1. Slide the water bottle cap onto the left rear hanger.

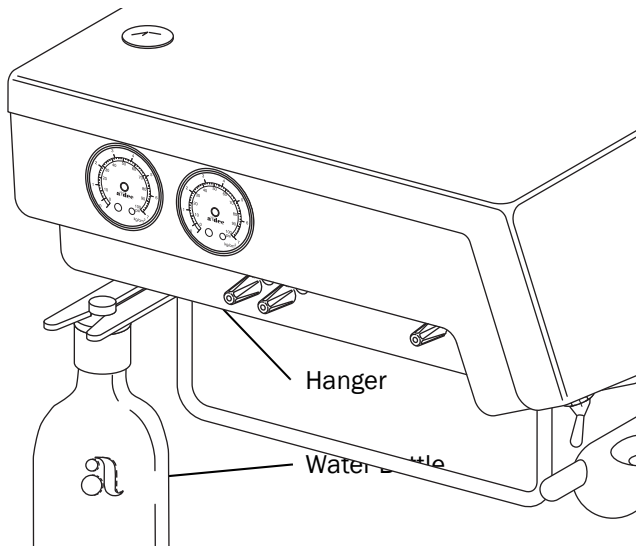

Install the Steril-Vac

1. Remove the Steril-Vac assembly from the case and mount it on the right rear hanger.

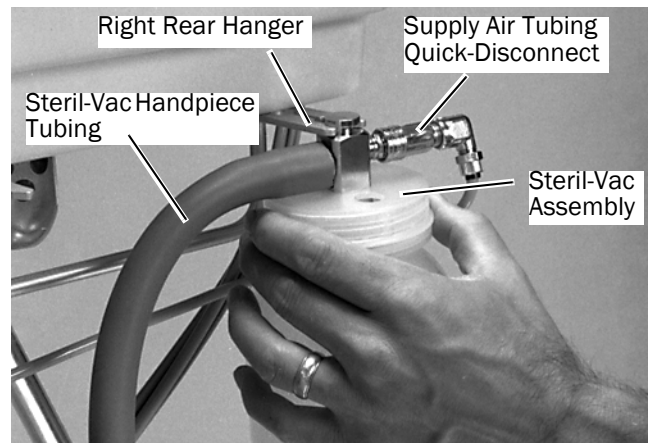

2. Place the Steril-Vac handpiece in a holder.
3. Route the supply air tubing from the control.
4. Connect the quick-disconnect to the Steril-Vac container.

Install the Optional Air Saliva Ejector

1. Remove the optional air saliva ejector from the case.
2. Place the air saliva ejector handpiece in a holder.
3. Connect the container to the remaining supply air tubing quick disconnect.
4. Mount the container on the right rear hanger.

Install the Tray Holder

1. Remove one of the plugs from the control head cover.

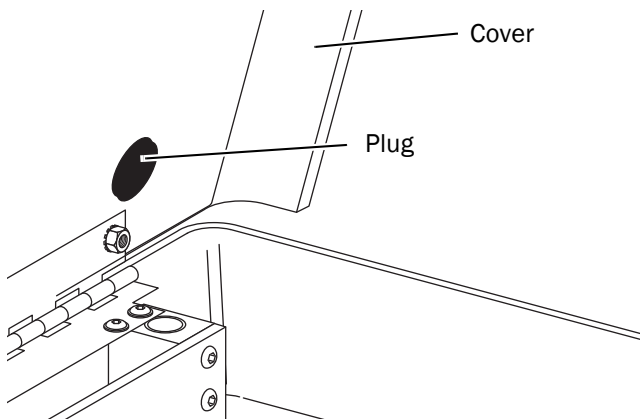

2. Place the mounting arm in the hole.

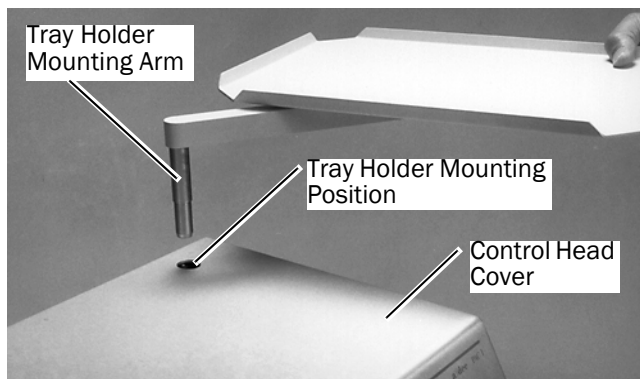

3. If the unit is equipped with an optional second tray holder, remove the remaining plug from the control head cover and install the second tray holder.
4. Place the tray(s) on the tray holder(s).

Connect the Supply Air Tubing

1. Locate the supply air tubing male quick-disconnect (QD) with automatic shutoff.

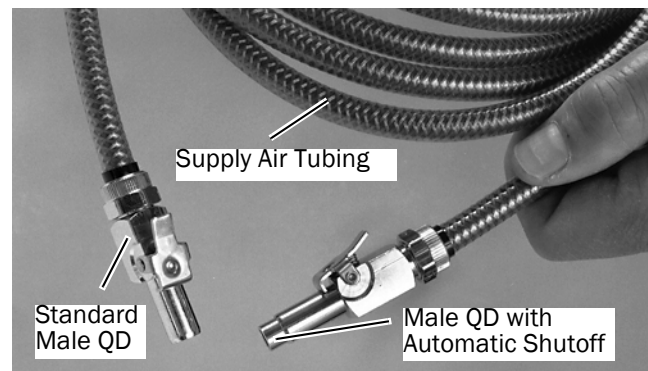

2. Attach the supply air tubing to the female QD on the base of the control head.

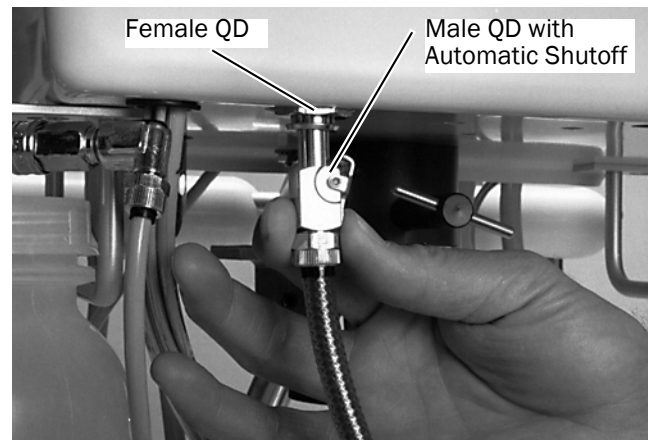

Pac I Field Repair Kit and (Optional) Tool Kit

There should be a field repair kit remaining in your carrying case or box.

Field Repair Kit



There is also a tool kit with your field unit. The tool kit is optional for institutional and self-contained units.

Tool Kit (Optional)



Refer to “Pac I Tool and Repair Kits” on page 43 for a complete listing of the items in these kits.

Testing Your Pac I Unit

1. Fill the self-contained water bottle with treatment water, and then screw the bottle into the cap. See “How to Choose Treatment Water” on page 17.
2. Turn on the unit.

Self-contained units

- (1) Plug the unit into a power outlet.

Field and institutional units

- (1) Connect the supply air tubing to a dry, filtered air source delivering 80-100 psi (552–690 kPa) of air at 4 SCFM (113 L/min).
The supply air pressurizes your unit, activating it for use.
- (2) If the unit includes a power supply, plug it into a power outlet.
3. Carefully check the unit and accessories for air or water leaks.
4. Attach the power cord to the power supply (only for use with A-dec quad-voltage, intraoral light source) and plug in.



NOTE For A-dec models 3420 Pac I (field unit, institutional unit, and self-contained unit), use only the A-dec power supply provided with your unit or A-dec p/n 45.1268.00.

5. Attach the handpieces. Your Pac I is ready for operation.

Repacking the Pac I Field Unit

1. Unplug the unit, if it has a power supply.
2. Field and institutional units: disconnect the supply air tubing from the air source.
3. Thoroughly clean the entire unit and accessories using the instructions in the following sections:
 - “Syringe Asepsis” on page 16
 - “Waterline Maintenance” on page 18
 - “Cleaning the Steril-Vac” on page 18
4. Reverse the setup instructions.



NOTE The standard tray holder and tray are packed face down with the mounting arm against the back of the case. The optional second tray holder and tray are packed face up with the arm positioned in the corner of the case.

Instructions for Use

About Your Pac I Dental Unit

Your A-dec Pac I dental unit is engineered to provide many years service, while requiring a minimum amount of attention. However, a certain amount of care is required. Conscientious adherence to these instructions will ensure reliable service from the Pac I.

The Pac I is a portable dental unit designed for field or operatory use. All facilities required for the practice of general dentistry are provided for both the doctor and the dental assistant.

The only external connection required is the supply air. A 10' (3048 mm) supply air hose is provided for this purpose. It may be connected to a compressor delivering, dry filtered air at 80-100 psi (552-690 kPa) at 4 SCFM (113 L/min), or to bottled gas (carbon dioxide or nitrogen) regulated to 80-100 psi (552-690 kPa).

The Pac I is offered in three configurations:

- Institutional unit
- Self-contained unit
- Field unit

About the Institutional Unit

The institutional unit includes an adjustable height mobile U-frame base and (optional) foot control carrier. The U-frame base has a 10-1/2" (267 mm) vertical adjustment, and is infinitely adjustable within its range. The top of the control head is adjustable between 27-1/2" (699 mm) and 38" (965 mm) from the floor.



About the Self-Contained Unit

The self-contained unit includes a fixed height mobile stand, a built-in compressor, and a duplex electrical outlet. The top of the control head is at a height of 33" (838 mm) from the floor.



About the Field Unit

The field unit includes a carrying case and a vertically adjustable tripod base. The top of the control head is adjustable between 26" (660 mm) and 32-1/2" (826 mm) from the floor.

The control head and accessories can be quickly disassembled from the base, and the entire field unit can be repacked into its carrying case for safe transportation or storage. The field unit, including carrying case and all accessories weighs 35 lb (15.5 kg).

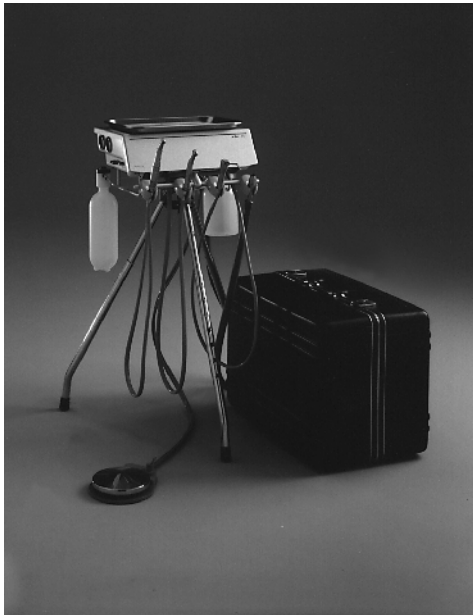

About the Field Repair Kit

All Pac I units include a field repair kit. Field units also includes a tool kit (optional for institutional and self-contained units). For a complete listing of the items in the kits, refer to "Pac I Tool and Repair Kits" on page 43.



Control Functions

Unit On/Off

To turn on your Pac I unit, connect the unit supply air tubing to the compressor or bottled gas. See "About Your Pac I Dental Unit" on page 10.



NOTE The unit must be operated with the cover closed.

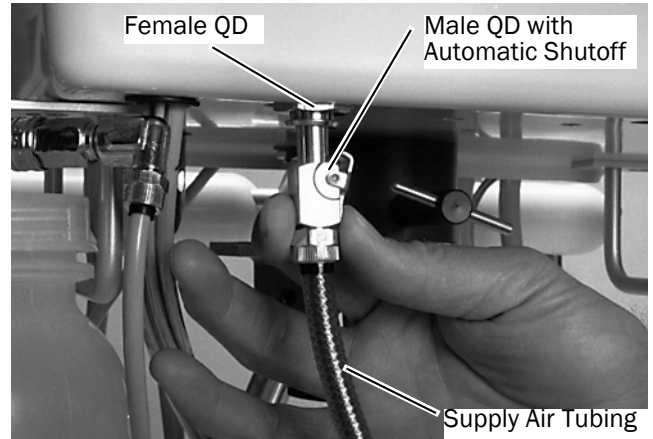

To turn off the unit, disconnect the unit from the compressor or bottled gas.

Handpiece Selector (if Equipped)

The handpiece selector controls which one of the two handpieces will be operated when you press the foot control disc.

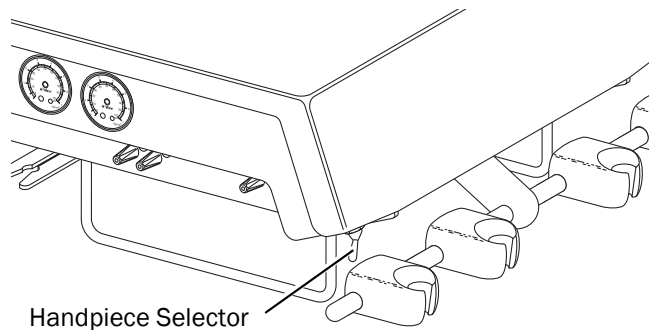

Drive Air Pressure Flow Controls

The drive air pressure flow controls are used to adjust the drive air pressure to each handpiece.

For instructions about adjusting the drive air pressure, refer to “Handpiece Drive Air Pressure” on page 13.

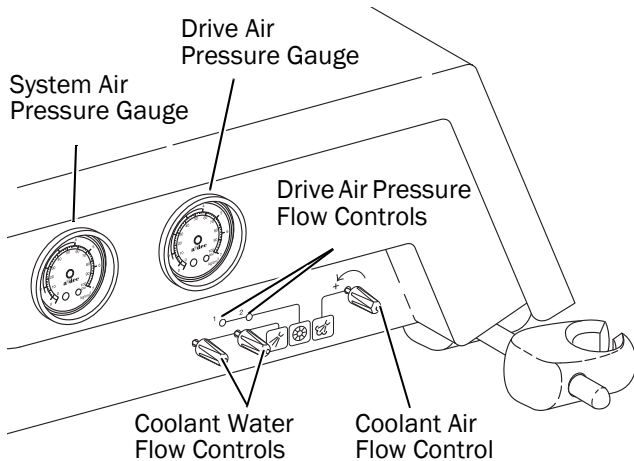

Coolant Air Flow Control

The coolant air flow control adjusts the flow of coolant air to both handpieces. Turned fully clockwise, it completely shuts off the coolant air. To adjust coolant air flow, refer to “Handpiece Coolant Air Flow” on page 13.

Coolant Water Flow Controls

The coolant water flow controls are used to adjust the flow of coolant water to each handpiece. To adjust coolant water flow, refer to “Handpiece Coolant Water Flow” on page 13.

Air Pressure Gauges

System Air Pressure Gauge

The system air pressure gauge displays air pressure coming from the air filter/regulator. The reading should be 70–80 psi (483–552 kPa). To adjust the system pressure, refer to “System Air Pressure” on page 13.

Drive Air Pressure Gauge

The drive air pressure gauge displays drive air pressure to the selected handpiece. Use this gauge to adjust the drive air pressure to the handpiece manufacturer’s specifications, as described in “Handpiece Drive Air Pressure” on page 13.



NOTE The accuracy of the gauge at 80 psi is ± 4 psi (552 kPa is ± 28 kPa).

Foot Control

The foot control modulates drive air to the active handpiece and provides air signal that activates the coolant air and coolant water flow. The foot control is operated by light foot pressure applied to any part of the foot control disc.

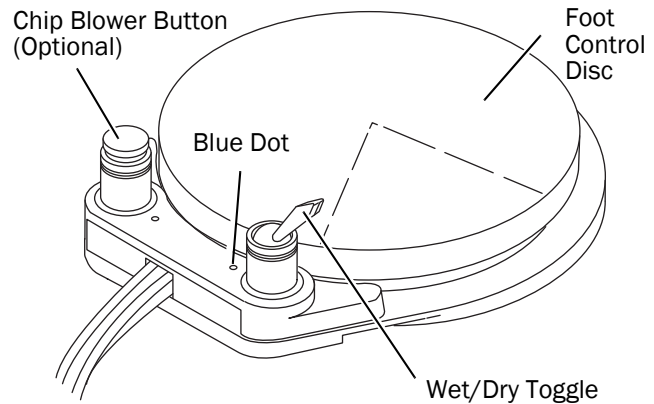

Wet/Dry Toggle

The wet/dry toggle allows you to shut off coolant water to the handpieces without moving your hands from the oral cavity.

Using your foot, move the toggle away from the blue dot to turn coolant water off. Move the toggle toward the blue dot to turn coolant water on.

Chip Blower Button (Optional)

The chip blower button is an option that sends a jet of air through the handpiece when it is not running.

Routine Adjustments

System Air Pressure

The air filter/regulator controls the system air pressure and is preset to 80 psi (552 kPa). If the system pressure is not 80 psi (552 kPa), lift the adjustment knob and turn. Clockwise increases pressure. When adjusting to decrease pressure, press the syringe air button before reading the gauge.

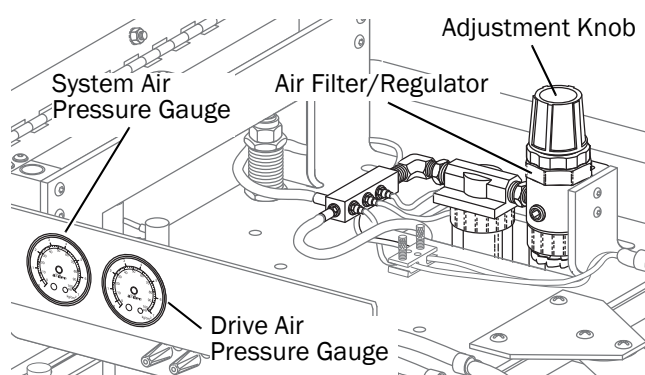

Handpiece Drive Air Pressure

Adjust the drive air pressure to meet the handpiece manufacturer's dynamic drive air pressure specification. Refer to the documentation that came with your handpiece for the dynamic drive air pressure specification.

You will need a 3/32" hex key to complete this adjustment.

1. Install a bur in the handpiece.
2. Locate the drive air pressure gauge and the drive air pressure control. See "Drive Air Pressure Flow Controls" on page 12.
3. Move the wet/dry toggle on the foot control to the Off position, away from the blue dot. See "Wet/Dry Toggle" on page 12.
4. Turn the drive air pressure flow control clockwise until the valve seats.
5. Fully depress the foot control disc.
6. While running the handpiece, watch the drive air pressure gauge and adjust the handpiece drive air pressure. Clockwise decreases the flow.
7. Repeat steps 1 through 6 for each handpiece.

Handpiece Coolant Air Flow

The coolant air flow control is used to adjust the coolant air flow to all handpieces.

You will need an adjustment key or a 1/8" hex key to complete this adjustment.

1. Install a bur in the handpiece.
2. Locate the coolant air flow control. See "Coolant Air Flow Control" on page 12.
3. Move the wet/dry toggle on the foot control to the Off position, away from the blue dot. See "Wet/Dry Toggle" on page 12.
4. Insert an adjustment key, or a 1/8" hex key, into the coolant air flow control.
5. Fully depress the foot control disc to activate the handpiece.
6. Adjust the coolant air flow to fit your needs. Clockwise decreases the flow. A strong flow of air is recommended.
7. The coolant air is set for all handpieces.

Handpiece Coolant Water Flow

The coolant water flow controls are used to adjust the flow of coolant water to each handpiece.

You will need an adjustment key or a 1/8" hex key to complete this adjustment.

1. Install a bur in the handpiece.
2. Locate the coolant water flow controls. See "Coolant Water Flow Controls" on page 12.
3. Move the wet/dry toggle on the foot control to the on position, toward the blue dot. See "Wet/Dry Toggle" on page 12.
4. Insert an adjustment key, or a 1/8" hex key, into the coolant water flow control for the handpiece being adjusted.
5. Hold the handpiece over a receptacle. Be sure to hold the handpiece so that the water will be directed away from you and into the receptacle. Then, fully depress the foot control disc to activate the handpiece.
6. Adjust the coolant water flow to fit your needs. Clockwise decreases the flow.
7. Repeat steps 1 through 6 for each handpiece.

Autoclavable Syringe

The A-dec autoclavable syringe is a three-way air and water syringe with a patented quick-disconnect autoclavable tip system.

The syringe is designed to be easily serviced on location. Repair instructions can be found under "Autoclavable Syringe Maintenance" on page 38.

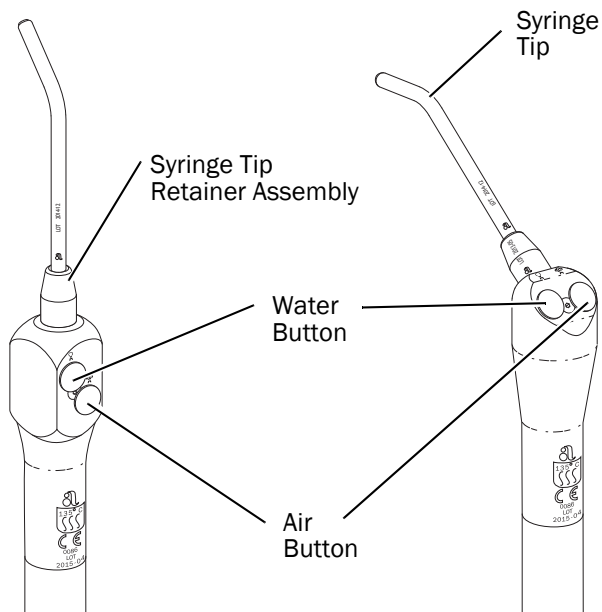

Water, Air, and Spray Functions

All A-dec autoclavable syringes have buttons that provide control of syringe water, air, and spray functions. For spray, press both buttons simultaneously



A-dec Syringe Tip

Your A-dec syringe is packaged with five specially designed A-dec syringe tips. These tips have three locking grooves which hold the tip in place when properly installed and prevent ejection of the tip during use. A-dec tips have the distinguishing mark of the A-dec "a" printed on them.

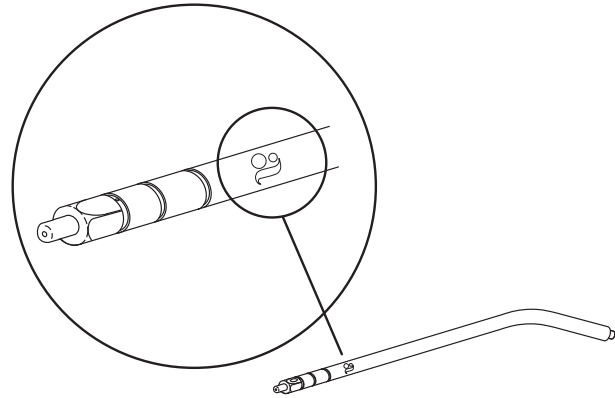

WARNING Use only A-dec syringe tips in A-dec syringes. A-dec syringe tips have been engineered and manufactured for use with A-dec syringes. Using syringe tips manufactured by a company other than A-dec may result in syringe tip ejection. Tip ejection may result in ingestion or aspiration of the tip, requiring immediate medical attention.

Install the Syringe Tip

The tip installation is the same for both the standard and locking retainer assemblies.



WARNING If you do not feel two clicks as you install the syringe tip, do not use the syringe. The O-rings inside the syringe tip retainer assembly are damaged and may allow the syringe tip to be ejected. Replace the O-rings before using the syringe.

1. Push the syringe tip into the syringe tip retainer assembly until you feel two clicks.

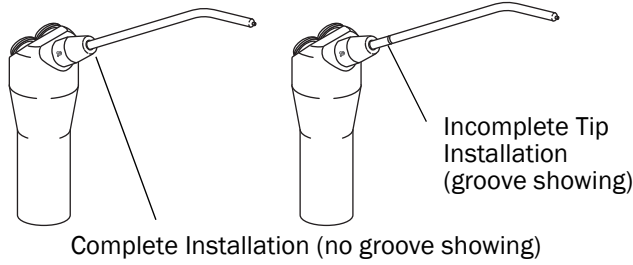

2. Point the syringe at the floor and press the air button several times to be sure the tip is properly installed.



TIP Remove the syringe tip by pulling the tip straight out of the syringe.



NOTE The non-locking retainer assembly is not appropriate for use as a cheek retractor because it allows the syringe tip to rotate.

Syringe Tip Retainer Assembly

A-dec syringes are factory equipped with a non-locking syringe tip retainer assembly. A locking retainer assembly is optional.

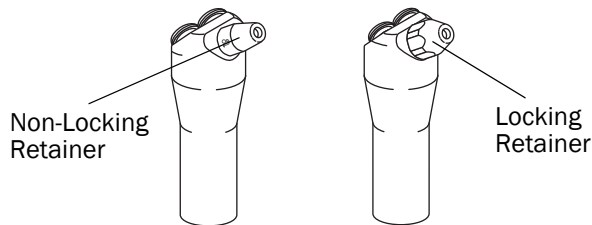

Non-Locking Retainer Assembly

The non-locking syringe tip retainer has a smooth exterior surface and allows you to easily remove and install the syringe tip.

Locking Retainer Assembly

The locking retainer has a hex-shaped exterior that allows the nut to be tightened, preventing the tip from easily rotating. The tip can then be used for cheek retraction.

Restrict the Tip Rotation

Your syringe tip rotates to spray in different directions. However, if you use your syringe tip for cheek retraction and you have the hex-shaped retainer nut, you may adjust the nut so the tip does not rotate easily.

1. Install the syringe tip. See “A-dec Syringe Tip” on page 14.
2. Use the plastic wrench provided with the hex nut to tighten the hex nut.

Ensure that the tip does not rotate easily.



CAUTION Tightening a hex retainer nut on an improperly installed syringe tip crushes the internal collet, making removal of the syringe tip difficult and installation of a new tip impossible.



TIP Remove the tip by turning the hex nut 1/4 turn counterclockwise and pulling the tip straight out of the syringe.

Quick-Disconnect Syringe Terminal

An A-dec quick-disconnect terminal allows you to remove a syringe from the delivery system without turning the system off.



A-dec Quick-Disconnect Syringe Terminal

Disconnect the Syringe

1. Turn off the master toggle.
2. Press the syringe air and water buttons to relieve the system air and water pressure.
3. Unscrew the syringe handle until the syringe head separates from the syringe terminal. When the syringe is disconnected, any water remaining in the syringe head drips out.



CAUTION Before disconnecting the syringe on units without a quick-disconnect syringe terminal, remove the self-contained water bottle. If the water bottle is located above the height of the syringe, water can drain out of the tubing.

Syringe Asepsis

All syringe tips are considered critical items and must be heat sterilized after each use. A-dec has designed syringes and syringe tips to be autoclavable or heat sterilized. Remove the syringe and syringe tips from the delivery system for sterilization.

Disconnect the Syringe

1. Turn off the master toggle.
2. Press the syringe air and water buttons to relieve the system air and water pressure.
3. Unscrew the syringe handle until the syringe head separates from the syringe terminal. When the syringe is disconnected, any water remaining in the syringe head drips out.

Precleaning

Preclean the syringe and tips before sterilization.

1. Gently brush the syringe threads with a nylon or brass bristle brush.
2. Remove the tip from the syringe.
3. Immerse the tip in a holding solution until ready for ultrasonic cleaning.
4. Clean the tip ultrasonically, following the ultrasonic manufacturer's instructions.
5. Purge all cleaning agents from the syringe and tip before sterilization.

Sterilization

Follow these steps to sterilize the syringe and syringe tip:

1. Rinse the syringe and syringe tips in clear water.
2. Flush the tips with isopropyl alcohol or Harvey's Vapo-Steril.

Heat sterilize the syringe and syringe tip using a steam autoclave for at least 4 minutes at a dwell temperature of 273°F (134°C).



CAUTION Sterilizing equipment at higher temperatures reduces the O-ring lifespan.

Syringe Flow Adjustment

The syringe air and water flow are controlled by a dual pinch valve located inside the control head.

To identify which adjustment screw controls the air flow and which controls the water flow, follow each length of tubing through the dual pinch valve. The syringe air tubing is connected to the air filter regulator manifold, and the syringe water tubing is connected to the red tubing inside the control head.

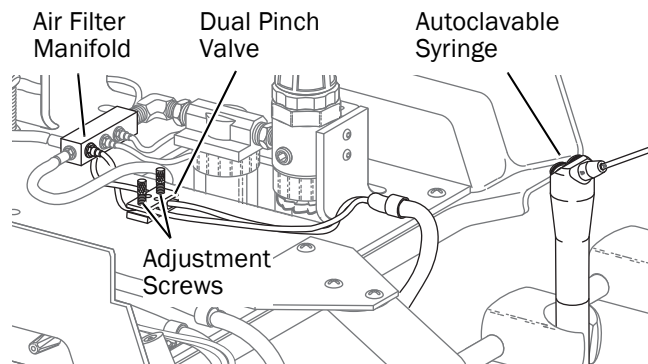

1. Adjust the water to achieve the desired rate of flow. Press the left (water) button on the syringe, and then turn the water flow adjustment screw. Clockwise decreases the water flow.
2. Press the syringe air and water buttons at the same time for spray, and then turn the air flow adjustment screw to achieve the desired spray. Clockwise decreases the spray.

Handpiece Tubing Flush System

Your handpiece control system is equipped with A-dec's handpiece tubing flush system. The system flushes more water through the tubings in less time than is normally possible when operating the foot control only. The handpieces should not be connected when flushing the tubings.

How Often Should I Flush the Handpiece Tubings?

At the Beginning of Each Day

Flush the tubings for 2-3 minutes.

After Each Patient

Flush the tubings for 20-30 seconds.

Flushing the Handpiece Tubings

1. Locate the handpiece flush toggle on the underside of the control head.

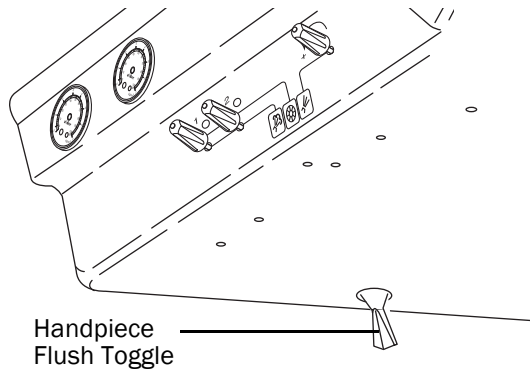

2. Gather up all the handpiece tubings that use water coolant and hold them over a water receptacle. Be sure you hold the tubings so that the water will be directed away from you and into the receptacle.

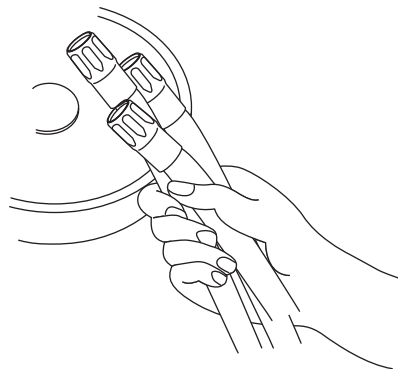

3. Move the flush toggle to the on position and hold for the appropriate time required, either for flushing between patients or flushing at the beginning of the day. Water flows only as long as you hold the toggle in the on position.
4. Replace the handpiece tubings in their holders.

Self-Contained Water System

How to Choose Treatment Water

The correct water to use in the A-dec self-contained water system depends on the quality of your municipal water. It's important to choose a source that consistently provides good water quality. For guidance, refer to the regulations specific to your location.

- **Tap Water** – If you have confidence in the quality of your municipal water supply, consider using tap water in your self-contained water bottle.
- **Bottled Water** – If you have concerns about the quality of your municipal water supply, use bottled water from a commercial source.
- **Softened Water** – In areas with hard water, greater than 200 mg/L as calcium carbonate (11.7 grains per gallon, 2.0 mmol/L), A-dec recommends the use of a water softener to prevent the buildup of mineral deposits that may impact the functionality of your delivery system.

Water Bottle Removal and Installation

Follow these procedures to properly remove, refill, and install an A-dec self-contained water bottle:

1. Use the master toggle to turn off the system.
2. Turn the bottle counterclockwise until the air seal breaks.
3. Remove the bottle by continuing to turn it counterclockwise.
4. Empty any remaining water from the bottle.
5. Wash your hands with soap and water, and wear new gloves before handling, filling, and installing the water bottle.
6. Drop an A-dec ICX[®] waterline treatment tablet into the bottle and fill with treatment water.



IMPORTANT Follow the instructions that appear on the ICX packaging.

7. Install the bottle by aligning it with the water bottle cap, making sure that the pick-up tube extends straight down into the bottle. Screw the bottle onto the cap until it is secure.



CAUTION Do not overtighten the water bottle or you may damage the components. It is normal to hear a pressurization sound after the system is turned on.

8. Turn on the system. Air fills the bottle.
9. Operate the syringe and handpieces to clear any air from the water system.

Waterline Maintenance

A-dec recommends a three-part protocol to maintain good water quality in your system: shock treatment, regular dental unit water monitoring, and the continuous use of A-dec ICX waterline treatment tablets. Use treatment products that are registered with the U.S. Environmental Protection Agency (US EPA). If you're located outside the U.S., contact your authorized A-dec dealer for product recommendations that are compatible with A-dec equipment.



IMPORTANT Follow the instructions that appear on the ICX packaging. For complete details on water usage in your A-dec system, see the *Waterline Maintenance Guide* (p/n 85.0983.00), which is available in the Document Library at www.a-dec.com.

Steril-Vac

Your A-dec Steril-Vac eliminates the need for a central vacuum. It is an air operated oral evacuation system using A-dec's air vacuum system (AVS) handpiece. Vacuum created at the handpiece forces the debris into the one-quart (.95 L) waste container. An optional two-quart (1.9 L) waste container is available.

Operating Your Steril-Vac

Air is supplied by attaching the quick-disconnect (QD) tubing to the steril-vac QD.

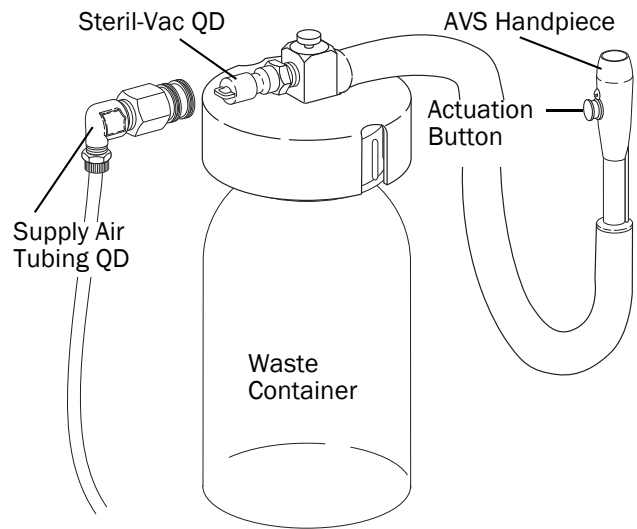

To actuate the vacuum, press and hold the button on the AVS handpiece. The button is spring loaded to the Off position.

Cleaning the Steril-Vac

After each patient, thoroughly rinse the Steril-Vac by drawing clean water through the AVS handpiece. After rinsing, draw air through the system for a few seconds to clear all water from the tubing.



NOTE Vacuum-lines should be cleaned at the end of each day by evacuating a detergent or water-based detergent-disinfectant through the system.

If you use barrier film to protect the main body of the AVS handpiece, replace the barrier film after each patient. Clean and disinfect this instrument at the end of each day or after each patient if the barrier film has been compromised. If you do not use barrier film, or if you perform oral surgery, always clean and disinfect the instrument after each patient.

Disinfection

To disinfect the AVS handpiece without disconnection from the vacuum system:

1. Remove the vacuum tip from the AVS handpiece.
2. Disinfect the AVS valve body assembly by using an intermediate-level disinfectant according to instructions for the disinfectant; A-dec recommends a phenolic (dual) water-based disinfectant.
3. Follow the manufacturer's instructions for disinfectant contact time.
4. Operate the AVS handpiece valve several times to verify that it rotates smoothly.

Disposable Tips

Heat sterilize stainless steel AVS tips after each use. If you are using disposable AVS tips, replace them with new tips after each use.



CAUTION Disposable AVS tips are not sterilizable and should not be reused.



Sterilizable Tips

To clean and sterilize a stainless steel AVS tip:

1. Remove the tip from the AVS.
2. Clean and rinse the tip using a mild detergent and water, then allow the tip to dry completely.
3. Sterilize at 132-134°C (270-273°F) for 4 minutes in a pre-vacuum sterilizer or at 132-134°C (270-273°F) for 6 minutes in a gravity displacement sterilizer.

Daily AVS Handpiece Cleaning

Daily cleaning of the AVS handpiece is necessary to prevent accumulation of debris. Several special cleaners with disinfectant properties for dental vacuum systems are available from dental supply dealers. If you use one of these cleaners, be sure to follow the manufacturer's recommendations. Never use a sudsing detergent to clean the AVS handpiece.

Use the brush provided in the field repair kit to clean the AVS handpiece. Push the brush all the way past the cross tube to clean the lower portion of the AVS handpiece. Rinse with clean water, and then hold the button down until all the water has been purged from the tubing.

Steril-Vac Waste Container

The Steril-Vac waste container should be cleaned and disinfected each time it is emptied.



DANGER Infectious waste may be present. Follow asepsis protocol to prevent cross contamination.

Oil Collection System

The gauze pad (2" x 2") inside the oil collector jar on your unit needs to be changed once a week for normal usage. Change it more often for heavy use.

1. Remove the oil collector jar from the unit and discard the old gauze.
2. Fold in quarters a new two-inch square gauze pad and place against the spring inside the jar.
3. Screw the oil collector jar onto the unit. Do not overtighten.

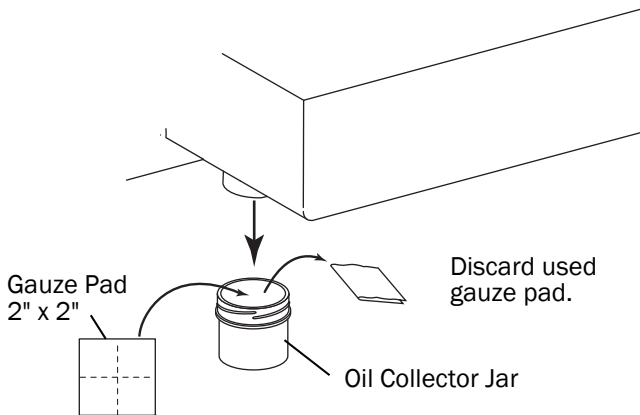

Care Instructions

For recommended asepsis instructions, refer to the *A-dec Equipment Asepsis Guide* (A-dec p/n 85.0696.00).

Barrier Protection

A-dec recommends barrier protection for all applicable touch and transfer surfaces. Touch surfaces are areas that come into contact with hands and become potential cross-contamination points during dental procedures. Transfer surfaces are areas that come into contact with instruments and other inanimate objects.

In the USA, barriers must be produced under the Current Good Manufacturing Practice (CGMP) as specified by the U.S. Food and Drug Administration (USFDA). For regions outside the USA, refer to the medical device regulations specific to your location.



NOTE For proper use and disposal of barriers, see the instructions provided by the barrier manufacturer.



IMPORTANT For recommendations on cleaning and chemical disinfection of touch and transfer surfaces (where barrier protection is not applicable or when barriers are compromised), please see the *A-dec Equipment Asepsis Guide* (p/n 85.0696.00).

Maintenance

General Service Information

Parts Inspection

In the troubleshooting sections in this manual you will find references to the “seal area” as a location for possible defect, which will allow a valve to leak. The seal area is comprised of the seal itself (usually an O-ring), the bore or seat in the valve body, and the seal groove in the valve stem or piston.

Defects in any of these areas may result in leakage. A careful examination of all sealing parts and surfaces with a magnifier is essential for detecting flaws that are too small to see otherwise.

When servicing components that have rubber gaskets or diaphragms it is generally advisable to install new ones when reassembling the components. If the old gasket or diaphragm is to be re-used, carefully inspect the item for pin holes or cracks.

Cleaning Internal Parts

When servicing dental systems, the parts of any component disassembled should be thoroughly cleaned and inspected for defects before reassembly. The lubricant recommended for these parts is largely impervious to chemical solvents. The most effective cleaner is a hot detergent solution. Any wiping should be done with a soft, lint free cloth. Flush all parts with clear, hot water and rinse them in isopropyl alcohol.

Tool and Repair Kits

Included with your Pac I unit is a field repair kit (p/n 45.0439.00). The Pac I field unit is equipped with a tool kit. If you have the Pac I institutional and self-contained unit and would like to order the tool kit, ask your dealer or call A-dec for the Pac I institutional or self-contained unit tool kit (p/n 45.0438.00). For a complete listing of the items in these kits, refer to “Pac I Tool and Repair Kits” on page 43.

The following items are not necessary but may be useful for Pac I maintenance and service.

O-Ring Tools

These tools allow quick field repair of most A-dec miniature components. The three tools in this set fit the four smallest O-ring sizes in A-dec equipment. Instructions for the use of the O-ring tools are included with the set.

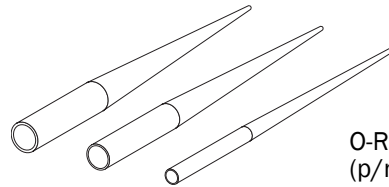

O-Ring Tools
(p/n 009.013.00)

Hemostats

Hemostats are useful for temporarily stopping air or water flow through the tubing while troubleshooting or repairing the unit.

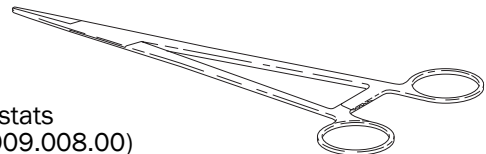

Hemostats
(p/n 009.008.00)

Valve Test Syringe

The valve test syringe is used to make quick tests of pilot-operated valves. The valve test syringe can be used to apply a static pressure of 5 psi (34.5 kPa) to 75 psi (518 kPa).



Valve Test Syringe
(p/n 98.0050.01, qty 4)

Test Gauge

The test gauge is used to check air pressure at various points while troubleshooting the system.

Also required for use of this gauge:

- One 1/8" (3.2 mm) barb (p/n 023.028.00)
- One flat nylon washer (p/n 004.005.02)
- One plastic tee (p/n 023.014.02, qty 10)
- Two uni-clamps for 1/8" (3.2 mm) tubing (p/n 025.007.01)
- 1/8" (3.2 mm) clear tubing, 2' (610 mm) long (p/n 024.015.04, qty 10')

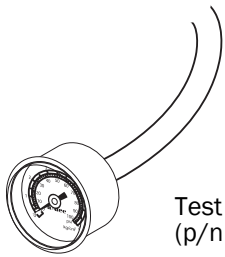

Test Gauge
(p/n 026.014.00)

Snap Ring Pliers

The snap ring pliers are used to install and remove both internal and external snap rings. It fits all the snap ring sizes used in A-dec equipment.

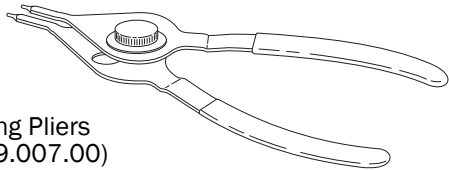

Snap Ring Pliers
(p/n 009.007.00)

Tubing Pliers

These modified pliers are used to push 1/8" (3.2 mm) tubing onto the barbed fittings.

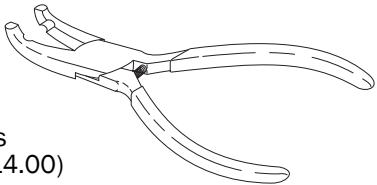

Tubing Pliers
(p/n 009.014.00)

A-dec Sleeve Tool (included in the tool kit)

The A-dec Sleeve Tool is used to press the 1/4" (6.4 mm) and 1/8" (3.2 mm) tubing sleeves in place when installing the tubing on barb fittings.

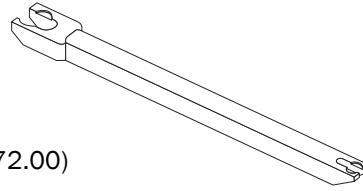

Sleeve Tool
(p/n 98.0072.00)

Hex Wrench Set (included in the tool kit)

A complete hex wrench set which includes all hex wrenches that might be required in servicing A-dec equipment. The plastic holder keeps the hex wrenches together and easily identifiable.

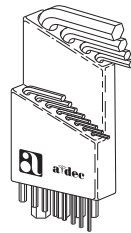

Hex Wrench Set
(p/n 009.018.00)

Lubrication (included in the field repair kit)

A-dec silicone lubricant is a high quality silicone base grease. It is ideal for lubricating internal moving parts, such as O-rings and oral evacuator valves.

Before installing O-rings always apply a light coat of silicone lubricant. This makes the installation of the O-ring easier and will prevent the O-ring from being damaged. An acceptable substitute for A-dec lubricant is Dow-Corning® No. 103 Silicone Lubricant.



Silicone Lubricant
(package of 6,
p/n 98.0090.01)

How Your Pac I Works

Your Pac I is engineered to provide many years of reliable service, even under the “less than ideal” conditions a portable dental delivery system may encounter. An important part of that engineering is the uncomplicated, straightforward design.

Refer to the flow diagrams on the following pages as you read this section.

The supply air (the only external connection required) attaches to the quick-disconnect (QD) at the bottom rear of the unit. The air goes directly to the air filter/regulator where it is filtered and regulated to 80 psi (552 kPa).

The air is then distributed from the air filter/regulator manifold to seven places: 2 QDs which supply the Steril-Vac and the (optional) air saliva ejector, the foot control, the water (air pressure) regulator, the system air pressure gauge, the syringe, and the handpiece selector valve, which relieves the holdback air to the control block of the handpiece selected (thereby making the selective handpiece active).

The foot control distributes the air to three places: the coolant air flow control valve, the Century II control system, and the (optional) chip blower button.

The Century II control system routes coolant air, coolant water, and drive air to the selected handpiece when the foot control disc is depressed.

Water is supplied by the self-contained water system. Air pressure, regulated to 40 psi (276 kPa), forces the water from the bottle to the Century II control system, the flush valve, and the syringe.

Waste water and debris are removed by the Steril-Vac and the (optional) air saliva ejector.

Manual Pac I Unit Flow Diagram

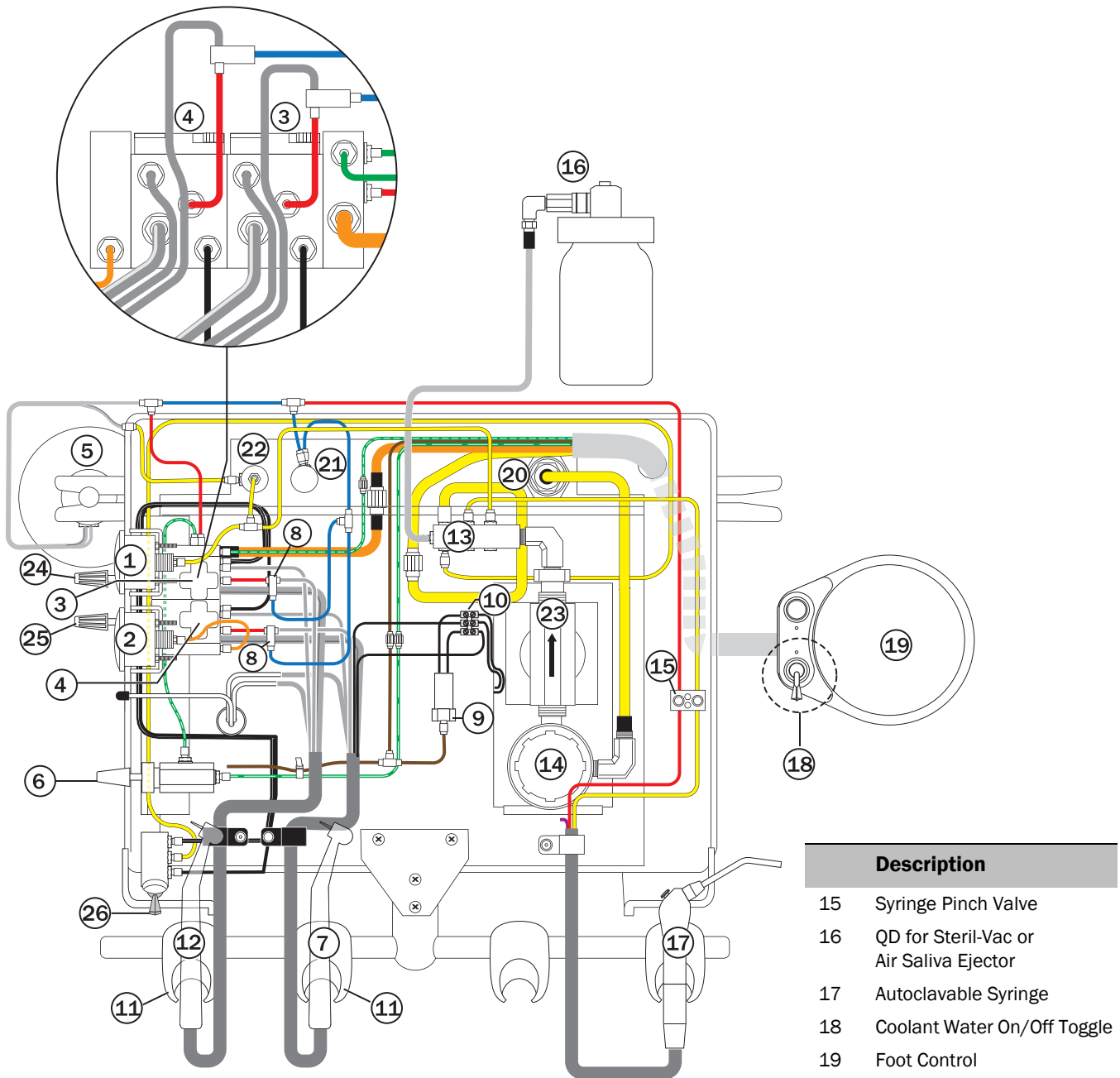

Description	
1	System Air Pressure Gauge
2	Drive Air Pressure Gauge
3	Control Block for Handpiece #1 (Item 12)
4	Control Block for Handpiece #2 (Item 7)
5	Water Bottle
6	Coolant Air Flow Control
7	Handpiece #2

Description	
8	Teed Check Valves
9	Air Electric Switch (optional)
10	Terminal Strip (optional)
11	Holder
12	Handpiece #1
13	Air Filter/Regulator Manifold
14	Air Filter Regulator

Description	
15	Syringe Pinch Valve
16	QD for Steril-Vac or Air Saliva Ejector
17	Autoclavable Syringe
18	Coolant Water On/Off Toggle
19	Foot Control
20	QD for Supply Air
21	Flush Valve
22	Water (Air Pressure) Regulator
23	Moisture Separator
24	Coolant Water Flow Control for Handpiece #1 (Item 12)
25	Coolant Water Flow Control for Handpiece #2 (Item 7)
26	Handpiece Selector

Auto Pac I Unit Flow Diagram

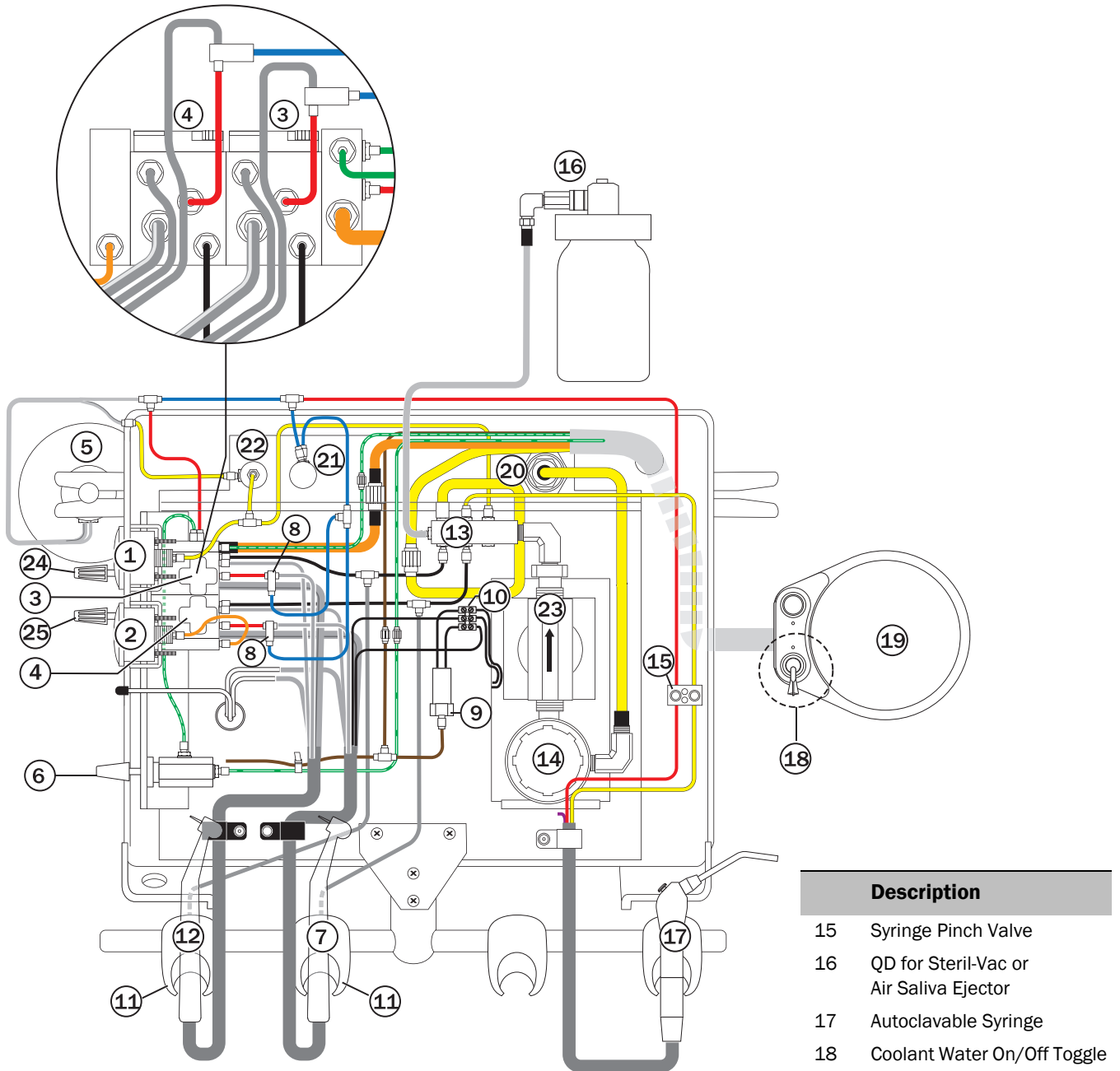

Description	
1	System Air Pressure Gauge
2	Drive Air Pressure Gauge
3	Control Block for Handpiece #1 (Item 12)
4	Control Block for Handpiece #2 (Item 7)
5	Water Bottle
6	Coolant Air Flow Control
7	Handpiece #2

Description	
8	Teed Check Valves
9	Air Electric Switch (optional)
10	Terminal Strip (optional)
11	Auto Handpiece Holders
12	Handpiece #1
13	Air Filter/Regulator Manifold
14	Air Filter Regulator

Description	
15	Syringe Pinch Valve
16	QD for Steril-Vac or Air Saliva Ejector
17	Autoclavable Syringe
18	Coolant Water On/Off Toggle
19	Foot Control
20	QD for Supply Air
21	Flush Valve
22	Water (Air Pressure) Regulator
23	Moisture Separator
24	Coolant Water Flow Control for Handpiece #1 (Item 12)
25	Coolant Water Flow Control for Handpiece #2 (Item 7)

Basic Troubleshooting

Given proper care, your Pac I will provide years of reliable service. In the event that something does go wrong with the unit, this troubleshooting section tells what can be done on location before removing the unit for repair.

This detail is not intended to isolate every problem that could arise. It is designed so you can quickly identify the problems that can be repaired without special training or equipment.

If the procedures given here do not identify and correct the problem, more detailed instructions are given in the sections covering the individual components of your Pac I.

Neither Handpiece Works (No Air or Water)

1. Does the syringe work?

Yes: Check for pinched or crimped foot control tubing. If the tubing is okay, refer to "Foot Control III Valve Maintenance" on page 33.

No: Proceed to Step 2.

2. Is the supply air (compressor or bottled gas system) turned on and functioning?

Yes: Proceed to Step 3.

No: Connect the supply air tubing and re-test the unit. If this did not correct the problem, consult the documentation that came with your compressor or bottled gas system.

3. Is the supply air tubing properly connected?

Yes: Refer to "Air Filter/Regulator Maintenance" on page 27.

No: Connect the supply air tubing and re-test the unit.

No Coolant Water from Either Handpiece

1. Does the syringe work?

Yes: Proceed with Step 2.

No: Verify that there is water in the self-contained water bottle.

2. Is the wet/dry toggle on the foot control in the on position (toward the blue dot)?

Yes: Proceed to Step 3.

No: Move the toggle to the on position (toward the blue dot) and re-test the unit.

3. Are the coolant water flow controls open?

Yes: Proceed to Step 4.

No: Set the coolant water controls as specified in Routine Adjustments. Then, retest the unit.

4. Does the handpiece coolant air work?

Yes: Refer "Century II Control Block Maintenance" on page 28.

No: Refer to "Signal Relay Valve Maintenance" on page 35.

Insufficient Drive Air Pressure

1. Does the problem affect both handpieces?

Yes: Proceed to Step 2.

No: Refer to "Handpiece Drive Air Pressure" on page 13.

2. Check the system air pressure gauge. Does it show a pressure of at least 70 psi (483 kPa)?

Yes: Proceed to Step 3.

No: Refer to "Air Filter/Regulator Maintenance" on page 27.

3. Watch the system air pressure gauge while pressing the syringe right-hand (air) button. Does the pressure drop by more than 15 psi (103 kPa)?

Yes: Remove and inspect the air filter. Refer to "Clogged Filter Element" on page 27.

No: Refer to "Foot Control III Valve Maintenance" on page 33.

Air Filter/Regulator Maintenance

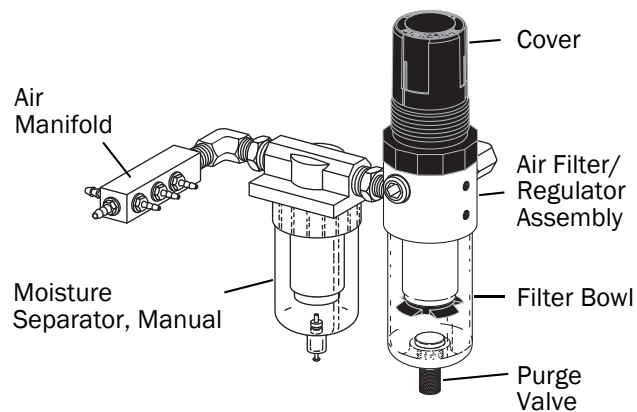

The supply air passes through the filter before entering the regulator. The filter element should be serviced when it becomes sufficiently clogged to impede the flow to the regulator.

Servicing the Air Filter/Regulator

The air filter/regulator assembly (24.0030.00) used in the Pac I is subject to only three types of problems: (1) clogged filter element, (2) external leakage, and (3) internal leakage.

To service any part of the air filter/regulator, first locate the Air Filter/Regulator Service Kit (p/n 90.1066.00), which is in your field repair kit. Included in the service kit is an exploded drawing of the assembly and replacement parts.

Checking the Filter

First, ensure the supply air is connected. Watch the system air pressure gauge while pressing the right-hand (air) button of the syringe. If the pressure drops by more than 15 psi (103 kPa), the filter element is clogged and must be replaced.

Clogged Filter Element

To replace the filter element:

1. Disconnect the supply air tubing from the control head.
2. Relieve system pressure by pressing the syringe air (right-hand) button, and by loosening the water bottle.
3. From the bottom of the unit, unscrew the bowl, remove the filter element and the filter element retainer.

4. Install the new filter element (97.0401.01) included in the service kit.
5. Reinstall the filter, retainer, and bowl.

External Leakage

In the event of external leakage, take the following action according to the point of leakage:

1. The leakage is coming from the purge valve at the bottom of the filter bowl.
The leak may result from a loose or defective purge valve.
 - Tighten the purge valve.
 - If the leak persists, replace the bowl assembly, which includes the purge valve (p/n 97.0403.00).
2. The leakage is coming from around the top of the filter bowl.
The leak may result from a loose filter bowl, or from a defective O-ring seal.
 - Tighten the filter bowl.
3. The leakage is coming from around the top of the regulator.
The leak may result from a loose cover or a defective diaphragm.
 - Tighten the regulator cover.
 - If the leak persists, replace the diaphragm (p/n 97.0402.00)

Internal Leakage

If the system air pressure gauge shows that pressure creeps up when the unit is not being used, there is air leaking past the inlet seal. This can normally be corrected by replacing the poppet (p/n 97.0402.00) and spring (p/n 97.0404.00) included in the air-filter regulator service kit (p/n 90.1066.00). When installing the new poppet, be certain there is no foreign material on the sealing surfaces in the valve body.

Century II Control Block Maintenance

The Century II control blocks control the routing of drive air, coolant air and coolant water to the handpieces. The control blocks are used in conjunction with the Century II manifolds, a manual selector valve, and a coolant flow control valve to make a complete control system.

Operating Principles

Each of the Century II control blocks has laterally drilled passages for drive air, coolant air, coolant water, and signal air. These passages line up with the outlet passages in the end of the Century II manifold.

Control Block (Front and Side Views)

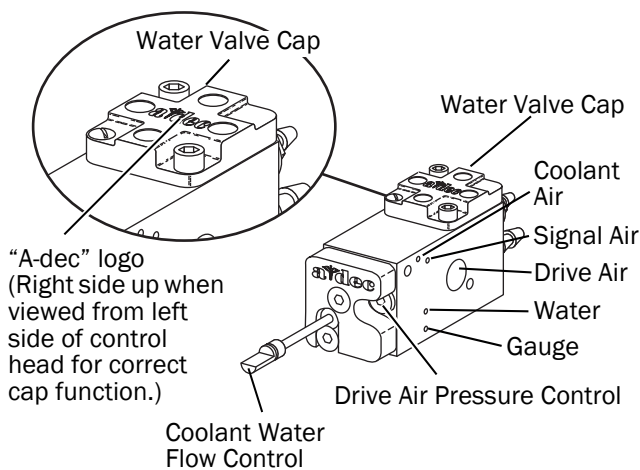

Control Block (Rear and Side Views)

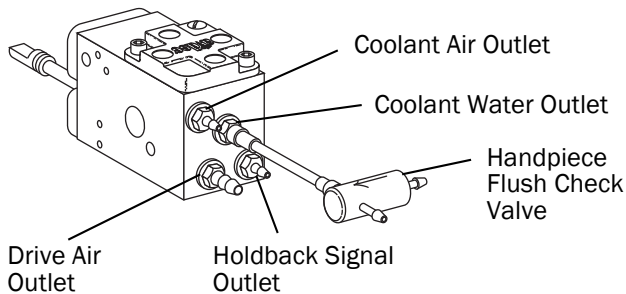

In each control block, the lateral passages for the drive air, coolant air, and signal air intersect with the longitudinal passages that lead to the front surface of the block. Parallel to these, other longitudinal passages lead to the handpiece drive air barb, the handpiece pressure gauge, the handpiece coolant air barb, and the cap for the water valve.

Control Block (Front Surface, Detail)

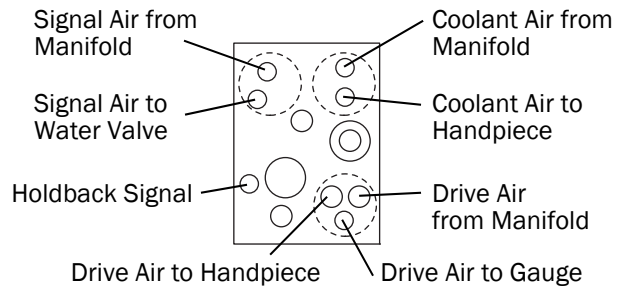

It is here, at the front surface of the control block, that the air from the foot control is either held back or allowed to flow through and run the handpiece.

The front cover of the control block has three cavities in the inner surface. As indicated by the broken lines, the cavities in the cover correspond in location to the three groups of passages drilled in the front of the control block. When the block is assembled, with the diaphragm in place between the control block and the front cover, the cavities allow the diaphragm to deflect away from the surface of the block, so air can flow between the grouped passages.

Control Block Front Cover (Inner Surface, Detail)

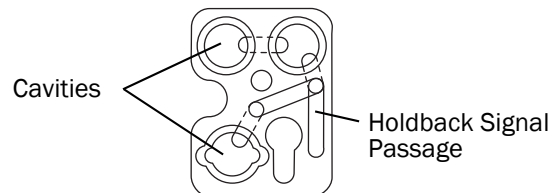

However, the flow between the grouped passages can occur only if the diaphragm is allowed to deflect into the cavities in the cover. Air pressure from the handpiece selector valve applied into the cavities presses and holds the diaphragm against the control block. This prevents any flow between the passages, so the handpiece cannot operate.

The handpiece selector valve supplies the holdback signal that pressurizes the cavities in the cover and shuts off the control block for the handpiece not being used. The selector valve releases the holdback signal to the control block for the handpiece selected, allowing air to pass through the block to the handpiece.

Coolant water for the handpiece is controlled by an integral water valve in the Century II control block.

Control Block (Water Valve Cross-Section)

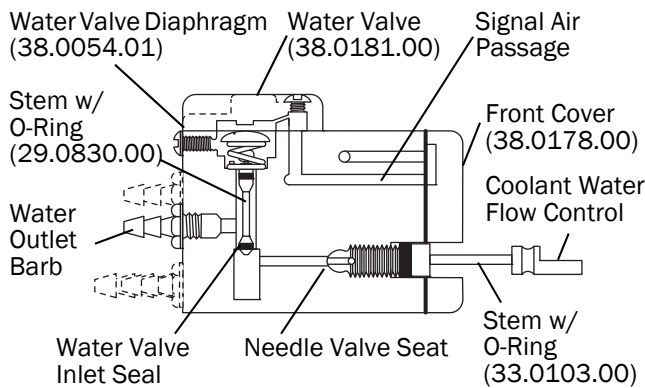

The water is supplied through a passage from the manifold. This passage intersects with the coolant water flow control needle valve bore. After passing the needle valve seat, the water flows to the inlet seal at the bottom of the water valve stem. Unless the water valve is actuated, the flow of water is blocked at this point.

Actuation of the water valve occurs when air pressure is applied above the water valve diaphragm, in the water valve cap. The signal air reaches the water valve cap after passing the holdback diaphragm at the front of the control block. When the signal air reaches the water valve cap, it deflects the diaphragm downward. This, in turn, pushes the stem downward and unseats the inlet seal, allowing water to flow through the valve to the outlet barb.

Releasing the signal air pressure allows the spring to push the stem and diaphragm back up, to close the water valve.

Century II Control Block Troubleshooting

This section takes you from symptom to corrective action. When servicing the control blocks, first locate the Century II, Pac I service kit (p/n 90.0043.00),

which is in your field repair kit. Included in the service kit is an exploded drawing of the control block and replacement parts.

Symptom	Possible Cause	Test Procedure	Corrective Action	
			If Test Is Normal	If Test is Abnormal
Audible air leakage from the control block area	Loose connections	Locate the exact point of leakage, using a soap solution if necessary. Tighten the tie bolt that secures the control blocks together and the screws that secure the water valve cap and front cover to the control blocks.	If no leakage is found on the control blocks, check the barb connections.	If tightening the fasteners fails to stop the leakage, proceed with the next step.
	Defective gasket, O-ring, or diaphragm seal	For leakage between the control blocks, replace the gaskets. For leakage between the block and the front cover, replace the holdback diaphragm. For leakage around the water valve cap, replace the water valve diaphragm.	If this stops the leakage, no further action is required.	If leakage continues, check for flaws in the sealing surfaces. Replace any defective parts.
Water leakage from the control block	Loose connections	Depending on the point of leakage, tighten the socket head screws that secure the cap to the top of the block, or the tie bolts that hold the control block together.	If this stops the leakage, no further action is required.	If tightening the fasteners fails to stop the leakage, proceed with the next step.
	Defective gasket or diaphragm seat	For leakage between the blocks, replace the gasket. For leakage around the water valve cap, replace the water valve diaphragm.	If this stops the leakage, no further actions is required.	If leakage continues, check for flaws in the sealing surfaces. Replace the defective parts.

Symptom	Possible Cause	Test Procedure	Corrective Action	
			If Test Is Normal	If Test is Abnormal
Air bubbles in the coolant water	Low water level in the water bottle	Check the water bottle to ensure it has an adequate supply of water.	If it does, proceed to next step.	Refill the water bottle.
	Loose fasteners	Tighten the socket head screws that secure the water valve cap to the control block, and tighten the tie bolt that secures the blocks together.	If this corrects the problem, no further action is required.	If there is still air in the water, proceed to the next step.
	Cross-leakage under the water valve diaphragm	Remove the cap from the top of the control block and carefully inspect the diaphragm and the surfaces of the block and cap.	If no defects are observed, install a new diaphragm. Re-assemble and test the unit.	Replace any defective parts. Re-assemble and test the unit.
Water drips continuously from the handpiece while the unit is not in use	Improperly installed water valve cap	Look at the top of the control block. The A-dec name should be right side up when viewed from the left-hand side of the unit.	If the cap is properly installed, proceed to the next step.	If it is wrong, remove the cap and install it correctly. Retest the unit.
	Water valve stem is stuck or has a defective return spring	Disconnect the supply air, and relieve system pressure by loosening the water bottle. Remove the cap and diaphragm from the control block. Press and release the water valve stem to check its freedom of movement.	If the stem seems to move freely, proceed to the next step.	If it sticks, remove the stem and inspect it for debris and defects. Replace any defective parts. Reassemble and test the valve.
	Defective inlet seal in the water valve	Remove the stem, and inspect the inlet seal O-ring.	If the O-ring is not defective, proceed to the next step.	Replace any defective parts. Reassemble and test the valve.
	Defective seat in the control block	There is no test to verify this, except the elimination of other possibilities as explained in the preceding steps.		Replace the control block. Reassemble and test the unit.
Air or water leaks from a handpiece that is not in use, only when another handpiece is being used	The holdback diaphragm is defective or improperly installed	Disconnect the air supply, and then remove the front cover from the control block for the leaking handpiece. Check for defects in the diaphragm.	If the diaphragm is not defective, proceed to the next step.	If the diaphragm is defective, install a new one. Reassemble and test the unit.
	Defect in the front surface of the block	Visually inspect the front surface of the block in the area of the air passages.	If no defects are visible, carefully reassemble the control block and test the unit.	If the surface is defective, install a new control block. Reassemble and test the unit.
Coolant sometimes sprays momentarily from the handpieces as the selector valve is turned	The foot control valve fails to exhaust when it is released	Refer to the instructions in "Foot Control III Valve Maintenance" on page 33 for the test procedures.		Take corrective action as indicated in "Foot Control III Valve Maintenance" on page 33.

Symptom	Possible Cause	Test Procedure	Corrective Action	
			If Test Is Normal	If Test is Abnormal
Restricted flow of air or water	Debris blocking internal passages	Check first for pinched tubing or other restrictions outside the Century II control block system.	If the signal relay is okay, look for a pinched or plugged tube between the signal relay and the handpiece control system.	Clean all debris from the barbs and passages. Make sure no tubes are crimped or pinched.
No coolant air or coolant water from either handpiece	Defective signal relay on the foot control	Refer to "Signal Relay Valve Troubleshooting" on page 35 and conduct the tests for "No signal from the signal relay valve."	If the signal relay is okay, look for a pinched or plugged tube between the signal relay and the handpiece control system.	
No coolant air from either handpiece (coolant water works properly)	The coolant air flow control is closed	Turn the coolant air flow control counterclockwise while running a handpiece.	If the coolant air starts flowing, adjust for the desired spray.	If this does not start the coolant air flowing, proceed to the next step.
	Obstructed air passage in the control block	Select one of the handpieces, and then step on foot control disc. If air comes from the handpiece, the control blocks are okay. If no air comes out, there is an obstruction in the control block.	If the test indicates the control blocks are okay, look for pinched tubing.	If the test indicates an obstruction in the control block, disconnect the supply air and remove the tie bolt. Use a wire to probe the passages and dislodge any debris. Reassemble and test the unit.

Symptom	Possible Cause	Test Procedure	Corrective Action	
			If Test Is Normal	If Test is Abnormal
No coolant air from one handpiece	Clogged tube in the handpiece	Switch the handpieces around and test each one, to determine whether the problem is in the handpiece or the control block.	If the problem is in the handpiece, clean or replace the coolant air tube.	If the problem is in the control block, proceed to the next step.
	Clogged passage in the control block	Disconnect the supply air, and then remove the front cover and diaphragm from the control block. Remove the coolant air outlet barb.	If no obstructions are found, check the handpiece tube and connector.	If there is debris in the control block passages, clean it out. Check the filter, and then reassemble and test the unit.
No coolant water from one handpiece	Closed coolant water flow control	Turn the coolant water flow control counterclockwise while running the handpiece.	If coolant water begins to flow, adjust the valve for the desired flow rate.	If there is no flow when the knob is turned fully counterclockwise, proceed to the next step.
	Improperly installed water valve cap	Look at the top of the control block. The A-dec name should be right side up when viewed from the left-hand side of the unit.	If the cap is properly installed, proceed to the next step.	If the cap is not properly installed, remove it and install it correctly. Retest the unit.
	Leaking water valve diaphragm	Remove the water valve cap and inspect the diaphragm for leaks.	If the diaphragm is not defective, check for clogged passages or barbs in the control block.	If the diaphragm is defective, install a new one. Reassemble and test the unit.

Foot Control III Valve Maintenance

The A-dec foot control III valve is actuated by foot pressure on the disc, which depresses the piston assembly in the valve bore. This displaces the poppet allowing air to flow to the outlet. When foot pressure is released, the piston returns, sealing the inlet at the poppet. Any pressure from the outlet side of the valve is then exhausted up through the middle of the piston.

For information about the signal relay valve, refer to "Signal Relay Valve Maintenance" on page 35.

When servicing the foot control, first locate the Foot Control III Service Kit (90.0593.00), which is in your field repair kit.



WARNING Before removing the foot control cover, disconnect the supply air and bleed all pressure from the system.

If the supply air must be active while testing the foot control, ensure that the valve stem cannot be ejected before connecting the supply air.

Foot Control III Service Kit (90.0593.00)

The Foot Control III Service Kit is included in your field repair kit.

Foot Control Valve

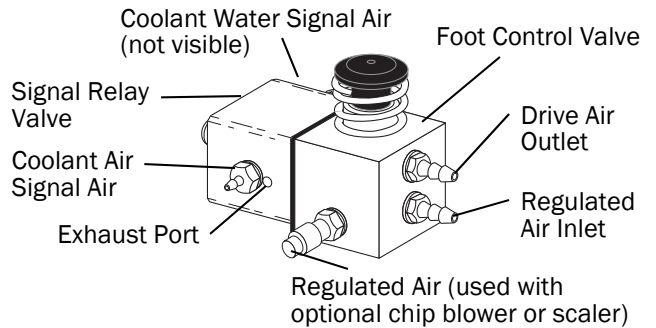

Control Block Front Cover

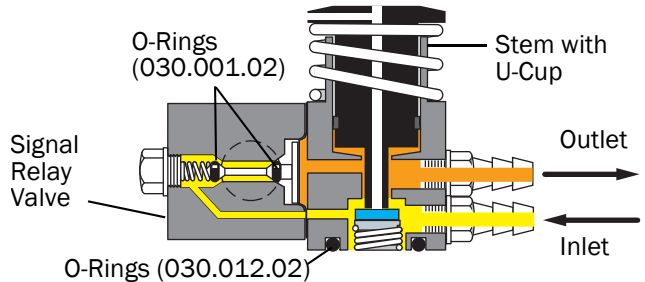

Foot Control III Valve Troubleshooting

Symptom	Possible Cause	Test Procedure	Corrective Action	
			If Test Is Normal	If Test Is Abnormal
Audible leakage while the foot control is not being used	Loose mounting screw	Turn the foot control face down and tighten the two socket head screws at the center of the foot control baseplate.	If the leakage stops, no further action is required.	If the leakage does not stop, proceed to the next step.
	Loose connection	Note the Warning on page 33. Remove the foot control disc and use a soap solution if necessary, to locate the source of the leakage. For leakage coming from the signal relay valve, refer to "Signal Relay Valve Troubleshooting" on page 35.	If the air is leaking around the barb connection, tighten the barb and re-test the valve.	If the air is leaking from the exhaust vent or around the bottom of the valve body, proceed to the next step.
	Defective O-rings or sealing surface	Disconnect the supply air, bleed the air pressure, and then disassemble the foot control. Inspect the O-rings on the signal relay stem and sealing surfaces for defects and debris.	If no defects are noted, carefully clean and lubricate the parts. Reassemble and test the valve.	Replace any defective parts. Carefully clean and lubricate all parts. Reassemble and test the valve.
Inadequate air flow from the foot control	Inadequate air flow to the foot control	Refer to the instructions for the air/filter regulator.	If these tests indicate there is adequate air in the system, proceed to the next step.	If any of the tests indicate a problem in the air supply to the foot control, take the corrective action recommended.
	Pinched tubing going to or from the foot control	Inspect the foot control tubing for crimps or restrictions.	If no problem is found, proceed to the next step.	If the tubing is crimped, install a new one and test the unit.
	Obstruction at the inlet or outlet	Note the Warning on page 33. With the cover removed, depress the piston and check for adequate air flow.	If no defects are noted, carefully clean and lubricate the parts. Reassemble and test the valve.	Replace any defective parts. Carefully clean and lubricate all parts. Reassemble and test the valve.
Foot control is sluggish	The stem is sticking	Note the Warning on page 33. Remove the valve body from the foot control baseplate. Remove and inspect the O-rings and piston for debris or defective parts.	If it works easily and smoothly, check for a weak or improperly installed spring.	If there is any sticking or binding, remove the stem, and O-rings. Replace any defective parts. Carefully clean and lubricate all parts. Reassemble and test the valve.

Signal Relay Valve Maintenance

The signal relay valve is a pilot operated three-way valve that mounts on the foot control valve body to provide handpiece coolant air and the handpiece water coolant signal. The valve is actuated by air pressure from the foot control valve outlet. This deflects the diaphragm and moves the stem to close the exhaust seal and open the inlet seal. A flow of air, at regulated supply pressure (80 psi [552 kPa]), passes through the signal relay valve to the outlet. When the

foot control is released, the diaphragm and stem return to their original positions, closing the inlet seal and exhausting any pressure at the outlet.



WARNING Before removing the foot control cover, disconnect the supply air and bleed all pressure from the system.

If the supply air must be active while testing the foot control, ensure that the valve stem cannot be ejected before connecting the supply air.

Foot Control Signal Relay Valve

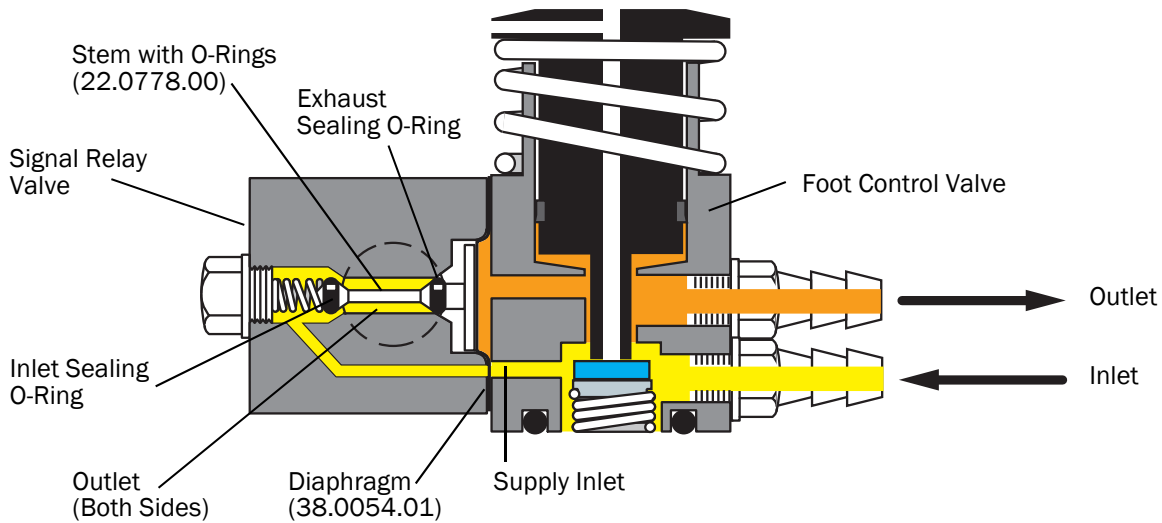

Signal Relay Valve Troubleshooting

Symptom	Possible Cause	Test Procedure	Corrective Action	
			If Test is Normal	If Test is Abnormal
No signal from the signal relay valve	The signal relay valve is installed upside down	Visually check the signal relay valve. It must be positioned as shown above, so the inlet passage lines up with the passage on the foot control valve body.	If the signal relay is properly installed, proceed to the next step.	If the signal relay is installed wrong. Remove it and install it properly. Retest the unit.
	Defective or improperly installed diaphragm	Remove the signal relay from the foot control and check for defects, debris, or improper installation. The holes in the diaphragm must be aligned with the passages in the valve body.	If do defects are noted, clean all parts. Reassemble and test the valve.	Replace any defective parts. Reassemble the valve, making sure all parts are properly installed.

Symptom	Possible Cause	Test Procedure	Corrective Action	
			If Test is Normal	If Test is Abnormal
Air signal from the signal relay does not shut off	The stem return spring is missing	Remove the hex plug from the end of the signal relay valve and verify that the spring is in place.	If the spring is there, proceed to the next step.	If the spring is missing or defective, replace it and retest the valve.
	The valve stem is stuck in the open position	Disassemble the signal relay valve and inspect all parts for defects, debris, or improper installation.	If no defects are found, carefully clean all parts. Lubricate the stem and O-rings, and then reassemble and test the valve.	Replace any defective parts. Lubricate the stem and O-rings, and then reassemble and test the valve.
Audible air leak while the unit is not in use	Improper seating of the diaphragm	Note the Warning on page 35. Use a soap solution, if necessary, to locate the source of the leakage.	If the leakage is from the exhaust holes on the sides of the signal relay, proceed with the next step.	If the leakage is at the diaphragm line, tighten the signal relay mounting screws. If leaking persists, replace the diaphragm.
	Signal relay inlet seal does not fully close	If the leakage is from the exhaust holes, disconnect the supply air, and then remove the signal relay from the foot control. Inspect the stem, O-rings, and seats for debris or defects.	If no defects are noted, carefully clean and lubricate the parts. Reassemble and test the valve.	Replace any defective parts. Clean and lubricate the parts, and then reassemble and test the valve.
Audible air leakage while the unit is in use	Improper seating of the diaphragm	Depress the foot control until the relay is actuated. While listening to the leak, depress the foot control all the way.	If there is no change in the sound of the leak, proceed to next step.	If the leaking increases with pressure on the foot control, tighten the signal relay mounting screws. If leakage persists, replace the diaphragm.
	Signal relay exhaust seal does not fully close	Note the Warning on page 35. While the foot control is depressed, check for leakage from the exhaust holes in the signal relay body.	If there is no leakage from the holes, check the outlet barb and tubing. Tighten the barb or the sleeve as necessary to stop the leak.	If air comes from the exhaust holes, inspect the exhaust seal area for debris or defects. Replace any defective parts. Clean and lubricate all parts, and then reassemble and test the valve.

Flush Valve Maintenance

A defective flush valve can cause two problems:

- Water leakage from around the flush valve toggle.
- Water dripping from the handpieces.

To service the flush valve, first locate the Century II, Pac I service kit (p/n 90.0043.00), which is in your field repair kit. Included in the service kit is an exploded drawing of the assembly and replacement parts.

Service the Flush Valve

1. Disconnect the supply air, and then loosen the water bottle.
2. Remove the hex nut and pull the flush valve assembly (p/n 33.0009.04) into the control head. It is not necessary to disconnect the tubing.
3. Remove the pin, and then remove the stem.

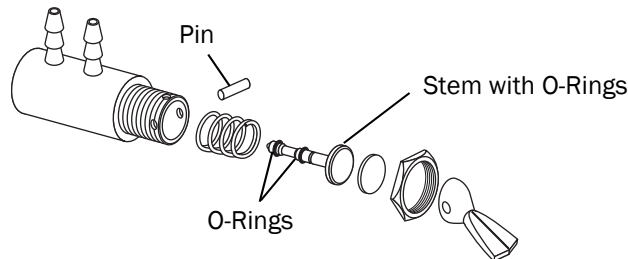

4. Check the O-rings and stem for defects and replace if necessary.
 - O-rings (p/n 030.001.02)
 - Stem with O-rings (p/n 29.0830.00)
5. Reassemble the valve and check for leakage.
6. If this does not correct the problem of water dripping from the handpieces, refer to "Century II Control Block Troubleshooting" on page 29.

Handpiece Selector Valve Maintenance

If you step on the foot control and both handpieces run, the problem could be a defective handpiece selector valve.

To service this valve, first locate the Century II, Pac I service kit (p/n 90.0043.00), which is in your field repair kit. Included in the service kit is an exploded drawing of the assembly and replacement parts.

1. Disconnect the supply air, and then bleed system pressure by operating the syringe.
2. Remove the hex nut and pull the valve assembly into the control head. It is not necessary to disconnect the tubing.
3. Remove the pin, and then remove the stem.

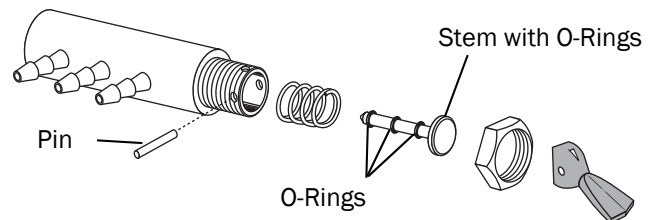

4. Check the O-rings (p/n 030.001.02) for defects and replace if necessary.
5. Reassemble the valve and test the unit.
6. If both handpieces still run, check the holdback air diaphragm and replace if necessary. Refer to "Century II Control Block Maintenance" on page 28.
7. If this does not correct the problem, replace the handpiece selector valve assembly (p/n 33.0104.05).

Autoclavable Syringe Maintenance

Your syringe is designed to be easily serviced in the operator. The syringe parts subject to wear under normal use are provided in your syringe service kit, located in the field repair kit.

Proper care and maintenance of your A-dec syringe is critical to ensure the safety of your patients and the reliability of this precision instrument.



NOTE Use only A-dec silicone lubricant; petroleum-based lubricants will cause malfunction or failure in O-rings.



NOTE Use only A-dec replacement parts to ensure the syringe functions properly.

Relieve System Air and Water Pressure

Before you begin working on the syringe, relieve the system air and water pressure.

1. Disconnect the air supply.
2. Use the syringe to bleed the system of air and water pressure.
3. Disconnect the syringe by turning the syringe handle counterclockwise until the syringe head separates from the handle and tubing.

Replace the Syringe Button Valves

1. Using a .050 hex key, remove the valve retaining screw.

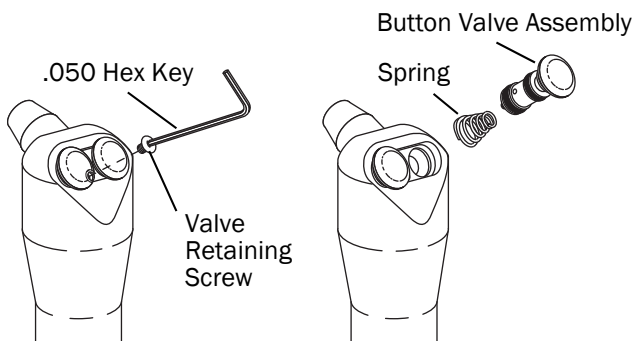

2. Discard the retaining screw, button valves, and springs.

3. Install the new springs with the small end out.

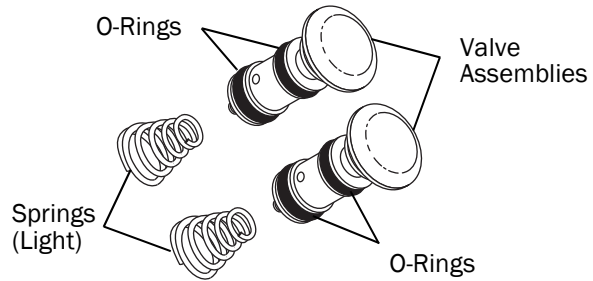

4. Lubricate the O-rings on the button valves and install them in the syringe.
5. Hold the button valves down so that the top of the spool aligns with the syringe head.

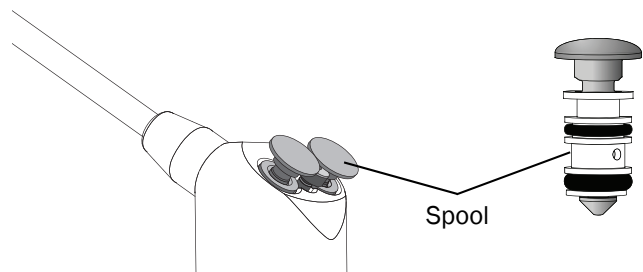

6. Install the retaining screw.

Replace the Syringe Tip Retainer Assembly

As a means of preventive maintenance, A-dec recommends you replace the two internal O-rings and the small O-ring in the syringe tip retainer assembly at least once a year. Lubricate the O-rings with A-dec silicone lubricant at the time of replacement.

1. Relieve the system air and water pressure. See page 38.
2. Use a 5/32" (4 mm) hex key to remove and discard the retainer assembly.



NOTE Verify there is one O-ring already installed on the spacer and two O-rings inside the nut.

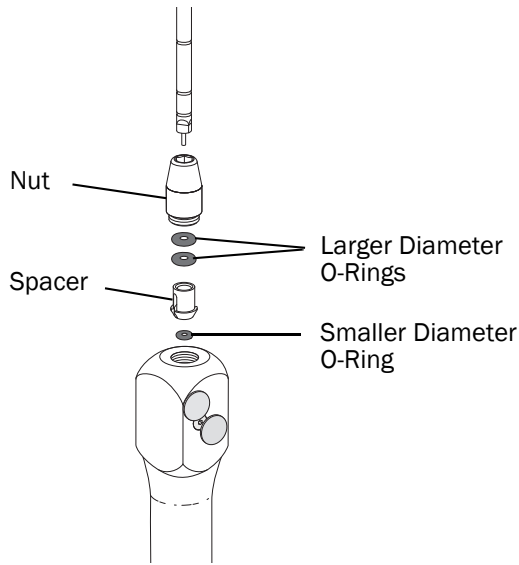

3. Install the new retainer assembly.
4. Install the A-dec syringe tip.

Replace the O-Rings on the Standard Syringe Terminal

1. Relieve the system air and water pressure. See page 38.
2. Turn the syringe handle counterclockwise to separate the syringe from the tubing.
3. Pull the syringe away from the terminal.
4. Remove the O-rings from the terminals.

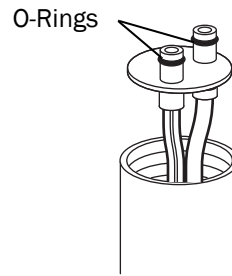

5. Lubricate and place the new O-rings on the terminals.
6. Reinstall the syringe.

Remove a Quick-Disconnect Terminal

1. Relieve the system air and water pressure. See page 38.
2. Turn the syringe handle counterclockwise to separate the syringe from the tubing.
3. Pull the syringe away from the terminal.
4. Remove the O-rings from the terminal stems.

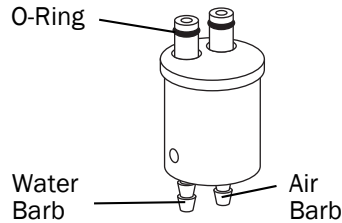

5. Label the air, water, and return-water tubing.
6. Remove the tubing from the barbs, retaining the metal sleeve clamps.

Rebuild a Quick-Disconnect Terminal

1. Relieve the system air and water pressure.
See page 38.
2. Use a .05" (1.27 mm) hex key to push the straight pin out of the bottom of the terminal.



NOTE The pin is installed with Loctite® and may be difficult to remove.

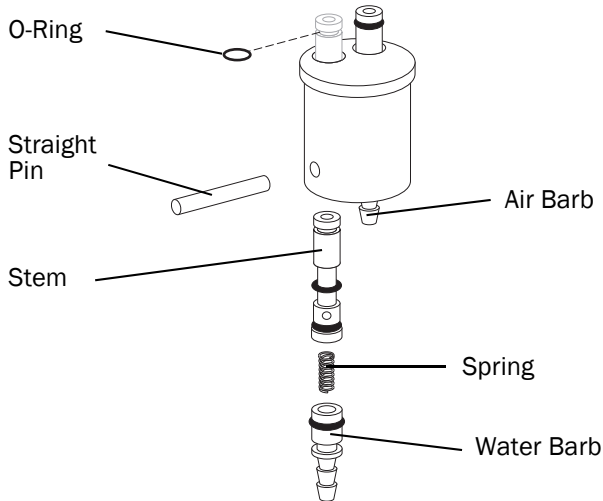

3. Discard the pin.
4. Remove the barbs from the terminal.
5. Push the stems and springs out of the bottom of the terminal and discard.
6. Apply A-dec Silicone Lubricant to the O-rings on the new stems and barbs.
7. Install the new stems, springs, and barbs in the terminal.
8. Install the new straight pin using Loctite.
9. Lubricate and place the new O-rings on the stems.
10. Use the metal clamps to secure the tubing to the terminal barbs.

Replace the O-Rings on the Connector Tubes

Follow these steps to replace the O-rings on the connector tubes.

1. Relieve the system air and water pressure.
See page 38.
2. Turn the syringe handle counterclockwise to separate the syringe from the tubing.
3. Pull the syringe away from the terminal.
4. Replace the O-rings on the connector tubes.



NOTE If the terminal connectors leak during testing, install an additional O-ring to each tube.

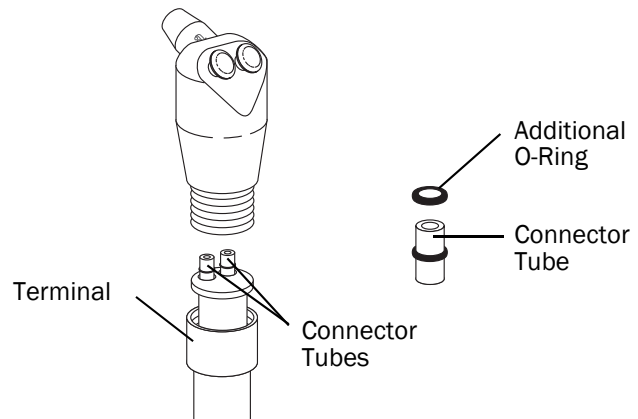

5. Reinstall the syringe to the terminal and tubing.

Syringe Troubleshooting

Problem	Possible Cause	Action
Syringe leaks air or water from a button	Faulty O-rings on the button	Replace the button assembly (p/n 23.1234.00)
Syringe tip drips when the syringe is not in use	Faulty O-rings on the water buttons	Replace the water button (p/n 23.1234.00)
A short burst of water sprays from the tip when the air button is pressed	Improperly installed or damaged syringe tip.	Pull out and reinstall the syringe tip correctly. Replace the syringe tip if it still leaks
Water or air leaks from the syringe handle	Syringe handle is not tightly connected to the syringe	Tighten the syringe handle onto the syringe
	O-rings on the terminal are damaged	Replace the O-rings (p/n 030.002.02) on the terminal and lubricate with A-dec silicone lubricant
Air leaks from the top of the tip retainer assembly	Syringe tip is damaged	Replace with a new tip (p/n 23.0872.01).
	Retainer internal O-rings are damaged	Replace the two inner O-rings (p/n 035.048.01) of the retainer assembly
Syringe tip is difficult to install	Retainer internal O-rings have been lubricated with a petroleum-based lubricant	Replace the O-rings (p/n 035.048.01) and remove remaining lubricant from the retainer. Use A-dec silicone lubricant on the new O-rings
	The tip retainer assembly has been damaged	Replace the tip retainer assembly (Non-locking: p/n 23.1112.00, Locking: p/n 23.1090.00)
Water leaks from base of tip retainer assembly	Tip is not fully installed	Push tip completely into place with the third groove hidden
	Small O-ring in the retainer assembly has failed	Replace the O-ring or replace the retainer assembly (p/n 034.003.01)
Syringe tip is loose in the retainer assembly	A non-A-dec syringe tip is in use	Replace with an A-dec syringe tip (p/n 23.0872.01)
	Retainer O-rings are worn or damaged	Replace the O-rings (p/n 035.048.01)

Customer Service

For service information, contact your local authorized A-dec dealer. When calling A-dec Customer Service, please have the lot number for the product available.

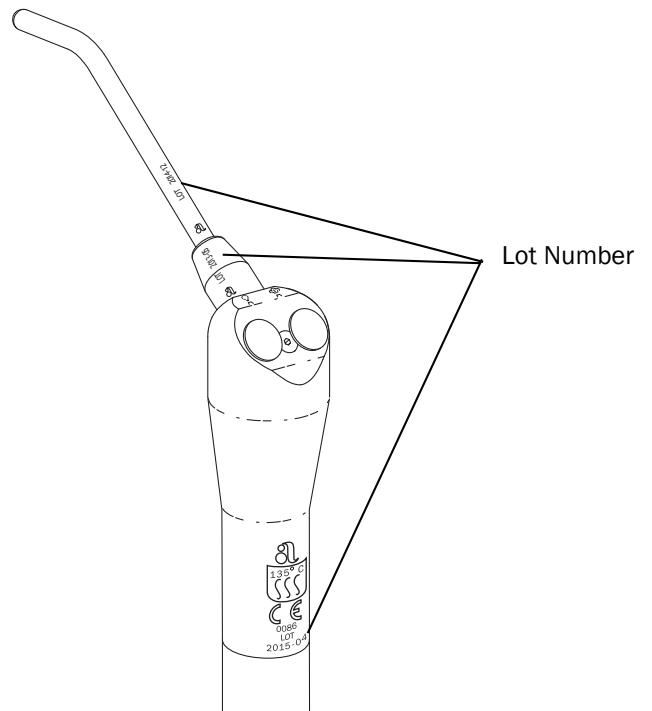

Steril-Vac Maintenance

Button Replacement

If air leakage develops around the AVS oral evacuator button, install a new button assembly. Your AVS Non-Locking Button Service Kit (p/n 10.0601.00) is in the field repair kit. It contains the new button with O-rings, a spring, and a tool for removing the old spring.

AVS Supply Air Tubing

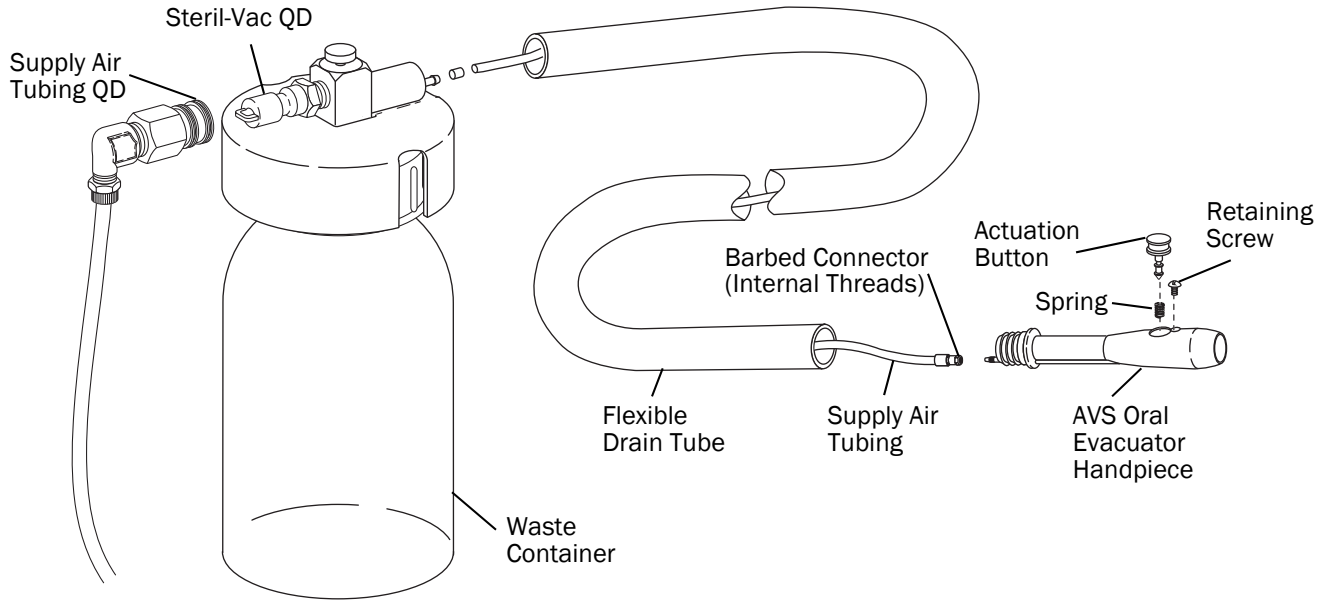

AVS Supply Air Tubing Replacement

The supply air tubing for the AVS oral evacuator is inside the flexible drain tube.

If the supply air tubing becomes crimped or develops a leak, install a new one as follows:

You will need an AVS Tubing Kit (p/n 10.0645.00).

1. Separate the Steril-Vac from the Pac I at the quick-disconnect.
2. Separate the flexible drain tube from the AVS oral evacuator handpiece and from the elbow on the waste container lid.
3. Unscrew the terminal nut from the AVS oral evacuator handpiece and disconnect the supply air tubing from the handpiece.
4. Remove the sleeve securing the supply air tubing to the elbow on the waste container lid and disconnect the supply air tubing from the elbow.
5. Discard the flexible drain tube, the supply air tubing, the sleeve and the terminal nut.
6. Connect the new supply air tubing to the AVS oral evacuator handpiece, and tighten the terminal nut.
7. Push the flexible drain tube onto the AVS oral evacuator handpiece.
8. Lay the tubing in a straight line, without stretching or compressing the flexible drain tube.
 - o Mark the supply air tubing at the point where the flexible drain tube ends.
 - o Cut the supply air tubing 1" (25 mm) short of the mark.
9. Slide the sleeve, from the kit, on the supply air tubing. Push the tubing onto the elbow on the waste container lid. Secure the connection by sliding the sleeve over the tubing and barb.
10. Push the flexible drain tube onto the elbow.
11. Reconnect the Steril-Vac to the Pac I at the quick disconnect, and check for leaks at the tubing connections.

Pac I Tool and Repair Kits

Field Repair Kit (p/n 45.0439.00)

AVS Non-Locking Button Service Kit (p/n 10.0601.00)

10.0109.00	Non-Locking On-Off Button Assembly
10.0440.00	Compression Spring
98.0030.00	Spring Removal Tool

Autoclavable Syringe Service Kit (p/n 23.1235.01)

011.038.01	Pin, Straight (pkg of 5)
013.003.01	Spring, Compression (pkg of 10)
013.064.01	Spring, Conical (pkg of 10)
030.002.02	O-ring (pkg of 10)
030.004.02	O-ring (pkg of 10)
035.025.01	O-ring, Special (pkg of 10)
23.0872.01	Syringe Tip (pkg of 5)
23.1064.01	Stem Assembly, w/O-ring (pkg of 2)
23.1068.01	Terminal Barb w/O-ring Assembly (pkg of 3)
23.1232.01	Valve Assembly w/O-ring (pkg of 2)
23.1112.00	Smooth Syringe Nut Assembly
23.1193.01	Screw, 2-56, Syringe (pkg of 5)
98.0090.01	Lubricant, Silicone (pkg of 6)

Air Filter/Regulator Service Kit (p/n 90.1066.00)

97.0402.00	Diaphragm/poppet, Pac I fltr-reg
97.0404.00	Spring, Pac I fltr-reg
97.0401.01	Filter Element (pkg of 3)

Foot Control III Service Kit (p/n 90.0593.00)

013.011.00	Helical Comp. Spring
030.012.02	O-ring (pkg of 10)
10.0440.00	Compression Spring
22.0060.00	Poppet, Plastic, Foot Control
22.0580.00	Spr, Comp, .312 OD x .25
22.0778.00	Stem w/O-rings, Signal Relay Valve
38.0054.01	Diaphragm (pkg of 50)
38.0760.00	Piston, FC3, Assy
98.0090.01	Lubricant, Silicone (pkg of 6)

Century II Service Kit, Pac I (p/n 90.0043.00)

002.097.00	Button Head Screw (4)
003.078.00	Socket Head Screw (2)
004.005.02	Flat Nylon Washer (pkg of 10)
011.038.01	Straight Pin (pkg of 5)
013.025.00	Helical Comp. Spring
022.029.02	Nut w/Sleeve, 1/4 ID (pkg of 10)
023.001.03	Barb 1/4 (pkg of 10)
023.004.03	Barb, 1/8 (pkg of 10)
025.007.01	1/8 Uni-Clamp (pkg of 10)
025.015.01	Sleeve Clamp, 1/4 ID (pkg of 10)
030.001.02	O-ring (pkg of 10)
030.004.02	O-ring (pkg of 10)
29.0830.00	Stem w/O-rings (3)
29.0831.00	Stem with O-ring (1)
33.0036.03	Lever, Toggle Valve, Momentary, Gray
33.0106.00	Stem with O-ring Micro Selector Valve
38.0054.01	Diaphragm (pkg of 50)
38.0179.02	Diaphragm (pkg of 10)
38.0186.02	Gasket (pkg of 10)
98.0090.01	Silicone Lubricant (pkg of 6)

Miscellaneous

023.019.03	1/8" Inline Barb (pkg of 10)
049.004.01	Bottle Brush, 3/4" Dia (pkg of 6)
11.0230.01	White, Disposable Tip (pkg of 100)
23.0872.01	Syringe Tip (pkg of 5)
98.0090.01	Silicone Lubricant (pkg of 6)

Tool Kit Pac I, P/N 45.0438.00

98.0072.00	Sleeve Tool (Plastic)
009.018.00	Hex Wrench Set
009.028.00	Phillips Screw Driver, 3/16 x 3" Shaft
009.029.00	Adjustable Wrench, 6"
054.030.01*	Plastic, Molded Case, White

* Part is available only in a kit.



 **A-dec Headquarters**

2601 Crestview Drive
Newberg, Oregon 97132
United States
Tel: 1.800.547.1883 within USA/CAN
Tel: +1.503.538.7478 outside USA/CAN
Fax: 1.503.538.0276
www.a-dec.com

A-dec Australia

Unit 8
5-9 Ricketty Street
Mascot, NSW 2020
Australia
Tel: 1.800.225.010 within AUS
Tel: +61.(0).2.8332.4000 outside AUS

A-dec United Kingdom

Austin House, 11 Liberty Way Nuneaton,
Warwickshire CV11 6RZ England
Tel: 0800.ADEC.UK (2332.85) within UK
Tel: +44.(0).24.7635.0901 outside UK



85.0681.00 Rev M
Date of Issue 2024-09-18
Copyright 2024 A-dec, Inc.
All rights reserved.
IFUsc5 adapted